

Local agent contact information

Abel Lift Contracting (Pty) Ltd

224 Voortrekker Street, Monument, Krugersdorp, 1739

E-mail: mark@liftcontractor.co.za

Tel: 011 660 7456 or Cell: 078 436 7729

Sino-Us Joint Venture



舒 马 克

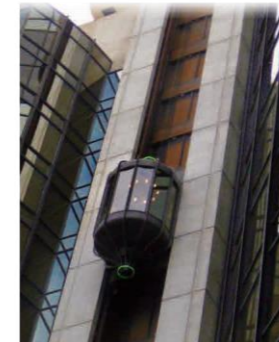
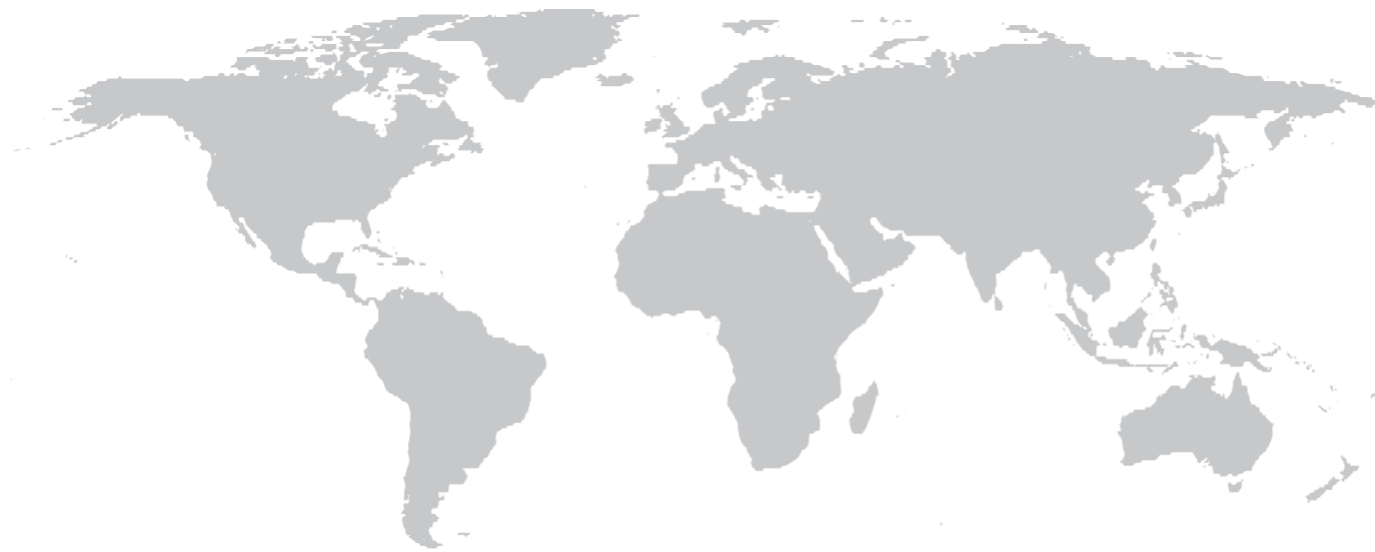

SCHUMACHER ELEVATOR (ZHANGJIAGANG) CO.,LTD.

Add: No.9 Binjiang Road,Zhangjiagang Free Trade Zone,China.
Tel: 0512-58318768 58331373
Fax: 0512-58333332
E-mail: office@sch-elevator.com.cn
Web: www.sch-elevator.com.cn
Post Code: 215633

SCHUMACHER ELEVATOR COMPANY

Add: One Schumacher Way Denver, Iowa 50622
Tel: (319)984-5676
Fax: (319)984-6316
Web: www.schumacherelevator.com

This publican is for general informational purposes and we reserve the right at any time to alter product design and specification. No statement if contains should be construed as a warranty or condition. Express or implied, as to any production, its fitness for any particular purpose of quality, or any modifications or representation of that term of any purchase agreement.
Feb 2017 version

SCHUMACHER
ELEVATOR (ZHANGJIAGANG) CO.,LTD.

About Schumacher

Schumacher USA

Schumacher elevator headquarters in American central Iowa, the company now has used in hydraulic elevator mezzanine and a complete production line of high-rise building elevator and escalator, is one of the most important, USA in high-rise building elevator supplier, in the national market share of more than 20%, at present Schumacher in North America, Europe and Asia has a production base.



Head office-Schumacher USA

Schumacher USA has been committed to research and development, have three research and development centers over the world, listed below:

Denver, USA - built a worldwide ultra high speed elevator tower experiment, by vibration, noise, pressure, etc. of tests to ensure the safety of ultra high-speed equipment and related parts.

Stuttgart, German - has a global pool of experts.

China - have academicians and experts workstations, postdoctoral, graduate students workstations, is one of the national drafting unit of elevator standard.



Founder William and Bertha Schumacher



Elmer and Earl Schumacher



Current CEO Marvin Schumacher

Schumacher China

Schumacher Elevator (Zhangjiagang) Co., Ltd. was established in 1992, belonged to Changjiang Runfa Group, professional manufacturer of elevators, escalators, moving walkways. In December 2002, Runfa group signed a joint venture agreement with Schumacher Elevator company, a nearly century-old elevator manufacturer in USA, Schumacher USA use of advanced elevator production technology, the performance of the products reach the world advanced level, the products are exported to more than 40 countries and areas, such as United States, Australia and so on.

The company now covers an area of 300 acres, plant area of over 100,000 square meters, more than 400 employees, with American engineers as technical director, with annual production capacity of 50,000 sets elevators and escalators. We use Schumacher USA's advanced management system, and apply on-site "6S" management model.



Sigbed into a joint venture

Schumacher History

1. In 1936 the design and manufacture of elevator
2. In 1948 to become the main supplier America heavy industrial elevator and elevator parts
3. In 1960 the design and production of the lifting platform cab and power device
4. In 1970 to expand production lines, as America commercial building, hospital, hotel and apartment building large supply of elevator and started the production and installation of high speed elevator.
5. In 1980 the microprocessor control unit to control the elevator
6. Founded in Austria in 1987 the European production base
7. In 1990 launched the home elevator and large public traffic type escalator
8. In 1996 the establishment of the Mexico production base
9. Changjiang Runfa group co founded in 2002 and China production base
10. In 2006 China factory output 3000, global output 20000
11. In 2010 China factory output 5000, global output 30000
12. In 2012 the capital of \$16800000
13. In 2013 China factory output 7000, global output 40000
14. In 2014 China factory output 10000, global output 48000
15. Replenishment of 49.8 million dollars
16. Start to rebuild 108 meter test tower



108 meter test tower



Schumacher china

Enterprise Qualification



Company Honor

Schumacher Elevator has passed the ISO9000 series certification, awarded the credible enterprises, Jiangsu Province AAA-level credible and trustworthy enterprises, China's elevator industry's top ten brands, green brand of choice for well-known international brands, high-tech products certificate, Jiangsu Province's new high-tech enterprises... and has about one hundred patents total, won the praise of the industry.



About Schumacher

Company Honor

Management System Certificate

About Schumacher



Patent Certificate



Production Device

Schumacher has the advanced production equipment, and fully ensure the product quality and reliability of products. Meanwhile, the company also actively introduces implementation lean production and other advanced production management methods. We are ready to work with our customer joint effort, and create a better tomorrow.





Workshop

Vertical Elevator Advanced Technology

Permanent magnetic synchronous gearless traction machine

Permanent magnet synchronous traction technology is a new generation of low-carbon energy saving elevator core technology researched by Schumacher and motor manufacturer. Compared with traditional technology, this technology is with low-carbon energy, less space, low construction costs and low operating cost characteristics; Meanwhile easily achieve machine none-maintenance requirements.

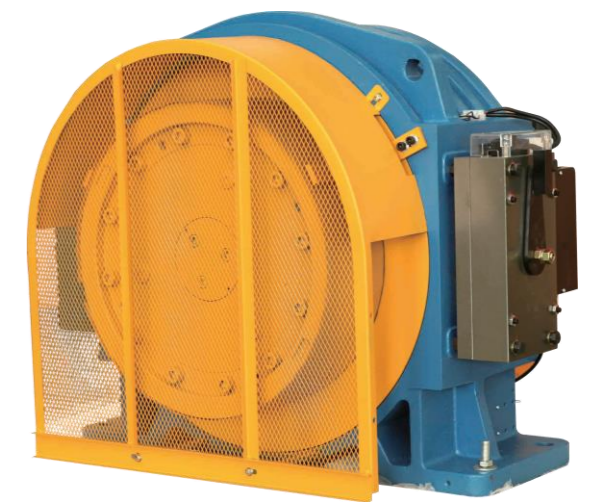

Vertical elevator
advanced technology

Low noise Space saving Low carbon Stable



A new generation of highly efficient vector elevator inverter

Schumacher elevator apply VVVF technology, the elevator running power and power supply capacity will be significantly reduced, compared to conventional AC speed drag energy, will save nearly 20%.

Apply high-performance current vector control and cosine encoders to achieve the torque compensation function, make the elevator more comfortable; elevator hoisting machine can be self-learning function, the elevator maintenance more simple and convenient; automatic torque boost function can easily cope with various elevator loads.



Inverter can automatically calculate the time, the shortest time positioning to reduce crawling time, the elevator run more efficiently, more smoothly. Short floor operation function, automatically crawling time reduced to a minimum.

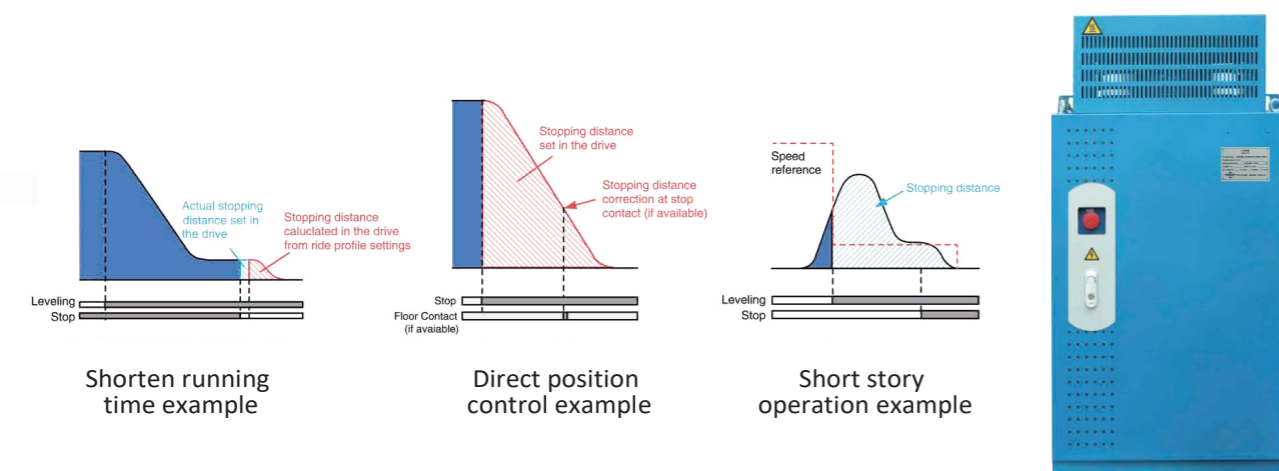

Integrated control, safe and more energy-efficient

Schumacher elevator control cabinet, apply the concept of integration between elevator control and drive, the lift run more safe and efficient, more energy efficient and environmentally. In the design fully consider the interests of its clients demands with high performance-based.

AC variable frequency door operator

Apply advanced technology VF door operator control systems, AC variable frequency motor and door mechanical system, not only to improve the safety and sensitivity of elevator operation, but also save energy consumption, adapted to the growing demands of modern transport.

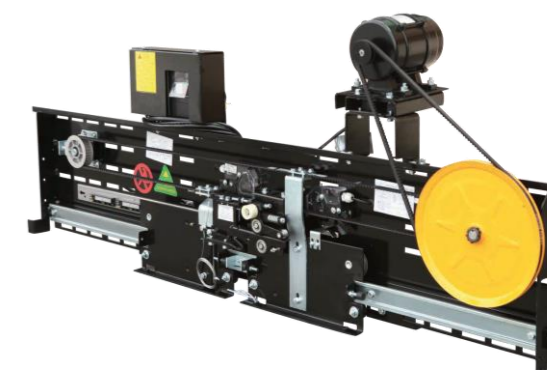

Deceleration curve comparison

VF observation elevator use vector frequency transformer to full closed-loop control the elevator, the elevator greatly improved performance, lower operating power consumption, has a very superior cost performance

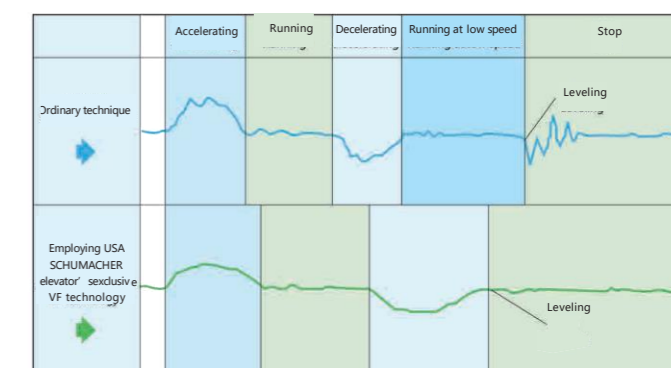

Vertical elevator advanced technology

Destination group control system

System features:

- Dynamically-scattered waiting
- Dynamic peak time zoning service
- Optional redeployment strategy
- Automatic peak time identification
- Configurable service layer
- Direct prediction function.



High Efficiency And Safety

It integrates various advanced dispatching technologies such as expert system, fuzzy logic and neural network, To ensure the high efficiency and safety of the elevator operation based on CAN BUS.

Comfort travel

Long waiting time can be effectively reduced by distributing the destination floor areas it also avoids the congestion and relaxes the anxiety of the passengers at waiting time.

Cost reduction

Efficiency can reduce the total number of building elevators, reducing the cost of building construction.

Energy saving and environment-friendly

Efficient scheduling of operations to reduce the total number of lift operations, reduce building energy consumption, energy saving.

Light Curtain Protection

Sensitive intensive infrared light curtains, form protection safety net in the elevator door, for any person or thing into its detection position, it will be sensitive reaction, greatly improving safety performance.

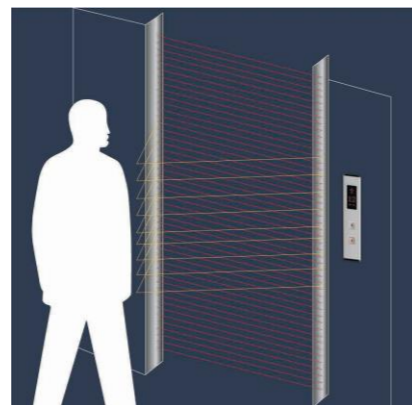

Remote fault diagnosis

Remote Guidance Module:

Can realize remote intelligent debugging and diagnosis module all functions. Human interface parameters to read and write, remote parameters to read and write, the expert system to help line debugging. Instead of PMT to obtain the vibration curve, remote experts to assist in judging the comfort of the test according to the vibration curve. Fault diagnosis, acquisition of elevator information, fault diagnosis more clearly. The maintenance of information integration platform, with the help of ESMS, the establishment of elevator information platform. To be informed in advance for elevator maintenance, elevator inspection management.

RIDS system advantage:

To grasp the quality of the installation and debugging in advance, reduce the cost and improve the efficiency of factory inspection. Supervise the site commissioning, and effectively manage the commissioning staff. Parameter preset, field free debugging. Remote read, save the elevator parameters and fault code, to enhance the management level of the elevator. Quickly diagnose the fault of the field, expert guidance, improve the efficiency of troubleshooting.

The diagnosis module:

The field diagnosis module does not require additional hardware. Fault intelligent diagnosis, fault code is more clear, more confidence in the fault of more abundant, easy to fault analysis. Self learning fault refinement, clear tips from learning fault state, to help the scene from the study. Fault mode, fault protection mode can be defined. Convenient maintenance fault phenomenon, check the fault code and the floor through the outbound board

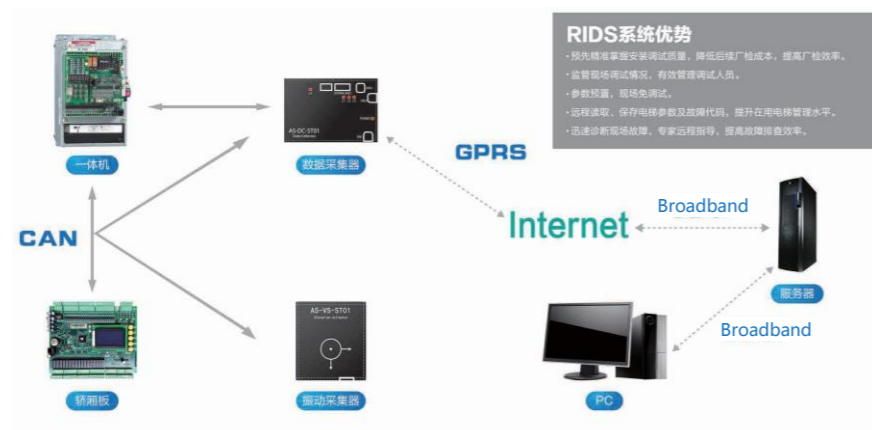

Long-distance Monitor Function

3G mobile communications and Internet network perfect combination, real-time acquisition computer board, converter data, wireless remote transport, achieve Internet remote monitoring.

Energy Feedback

Schumacher adheres to energy-saving and environmental protection product-development ideas. It creatively applies energy feedback technology to passenger elevator. It applies the most advanced energy regenerating theory in the world and effectively converts potential energy in the elevator running to electric energy so as to feed back to electric grid. It greatly reduces the harmonic pollution to power source and fulfills re-generation and re-utilization of the energy.

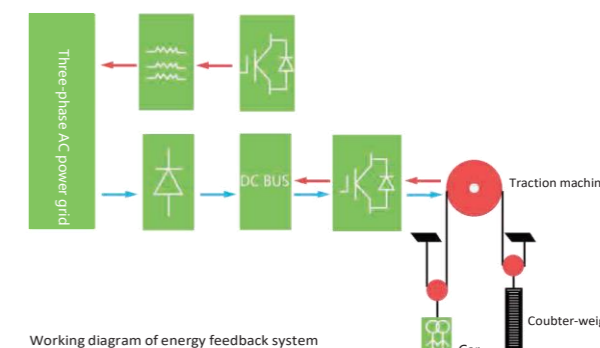

Vertical elevator advanced technology

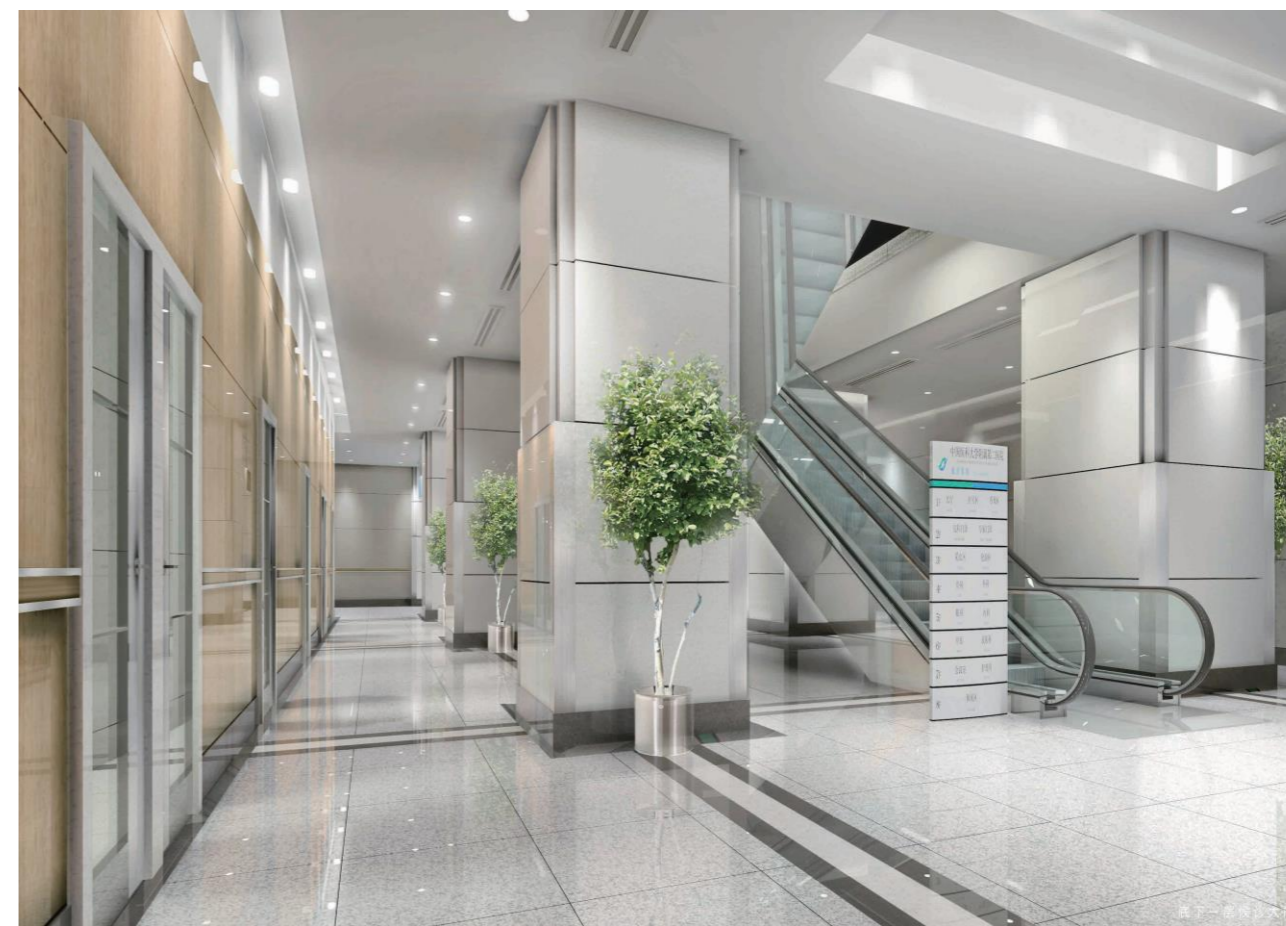

Function table

Standard function

 Travel function	VVVF drive	Motor rotating speed can be precisely adjusted to get smooth speed curve in lift start, travel and stop and gain the sound comfort.
	VVVF door operator	Motor rotating speed can be precisely adjusted to get the more gentle and sensitive door machine start/stop
	Independent running	According to the users' needs, the lift cannot respond to outer calling, it only responds to inner command in the car.
	Automatic pass without stop	When the car is crowded with the passengers or the load is close to preset value, the car will automatically pass the calling landing in order to keep maximum travel efficiency.
	Adjust door opening time	Door opening time is apt to the users' demands.
	Reopen with hall call	IN the door shutting process, pressing the hall call button can reopen the door
	Express door closing	When the lift stops and opens the door, press door-shut button, the door will be closed immediately.
	Car stops and door open	The lift decelerates and levels, the door only opens after the lift comes to a complete stop.
	Car arrival gong	Arrival gong in the car top announces passengers the car's arrival.
	Anti-nuisance	In the light lift load, when three more commands appear, all the registered callings in the car will be cancelled, in order to avoid the unnecessary parking.
	Automatic return to home	In low traffic flow, the car which has no call will return to the main floor, shut the door and keep waiting automatically.
	Command register cancel	If floor command button in the car is pressed by mistake, press same button again to cancel the registered command.
	 Safety function	Photocell protection
Designated stop		If the lift can not open the door in the destination floor out of some reason, the lift will close the door and travel to the next designated floor.
Overload holding stop		When the car is overloaded, the buzzer rings and the lift remains at rest in the same floor.
Anti-stall timer protection		The lift stops operation due to slippery traction wire rope.
Start protection control		If the lift does not leave door zone within the designated time after it gets started, it gets started, it will stop the operation.
Inspection operation		When the lift enters into inspection operation, the car travels at inching running.
Fault self-diagnosis record		With the help of this record function, faults can be restored rapidly so that the lift can remove in a shot time.
Sill impurity removal		If the lift door can not shut due to sill impurity or interference, it reopens/re-shuts in the stipulated time and remove the impurity.
Up/down over-run and final limit protection		The device can effectively prevent from the lift's surging to the top or knocking the bottom when it is out of control. If results in more safe and reliable lift travel.
Down over-speed protection		When the lift downs 1.2 times higher than the rated speed, this device will automatically cut off control mains, the motor running so as to atop lift down at over-speed. If the lift continues to down at over-speed, and the speed is 1.4 times higher than rated speed, safety tongs act to force the lift stop in order to ensure the safety.
Upward over-speed protection device	When the lift up speed is 1.2 times higher than rated speed, the device will automatically decelerate or brake the lift.	
 Man-machine interface	Micro-touch button for car call and hall call	Novel micro-touch button is used for operation panel command button in the car and landing calling button.
	Floor and direction indicator	The car shows the lift floor location and current travel direction.
	Floor and direction indicator in hall	The landing shows the lift floor location and current travel direction.

 Emergency function	Emergency car lighting	Emergency car lighting automatically activated once power failure.
	Inching running	When the lift enters into emergency electric operation, the car travels at low speed inching running.
	Five way intercom	Communication amid car, car top, lift machine room, well pit and rescue duty room through walkie-talkie.
	Fire alarm	In emergency conditions, if bell button on car operation panel is continuously pressed, electric bell rings on top of the car.
 Emergency function	Car ventilation, light automatic shut off	If there is no calling or command signal within the stipulated time, the car fan and lighting will be automatically shut-down in order to save the energy.

Optional function

 Emergency function	Leveling when power failure	In normal power failure, the chargeable battery supplies the lift power, The lift drives to the nearest landing.
	Fire emergency return	If you start emergency switch in main landing, all the callings will be cancelled. The lift directly and immediately drives to the designated rescue landing and automatically opens the door.
 Travel function	Direct parking	According to distance principle completely, the car can directly level without crawling, It greatly enhances the operation efficiency.
	Group control function	The group control system is used when three or more same model lifts are organized into a group to run, it can make the lift group automatically choose the most appropriate response, avoid repeated parking, reduce the passengers' waiting time and increase the operation efficiency.
	Duplex control	Two sets of same model lifts can unanimously respond the calling signal through the computer dispatch, In this way, it reduces the passengers' waiting time to the greatest extent and enhances the travel efficiency as well.
	Energy feedback device	Feeding the energy generated during the lift running and braking back to reduce the customers' operational cost and environmental pollution.
	Lift stop function	If the lift waits for certain period of time without travel, it automatically stops to save power.
	Door open time extending	Press special button in the car, the lift door deeps open for certain period of time.
 Man-machine interface	Voice announcer	When the lift normally arrives, voice announcer informs the passengers about the relevant information.
	Car assistant operation box	It is the large loading weight lifts or the lifts with crowded passengers so that most of the passengers can operate the car easily.
	Intelligent calling service	Destination floor calling can be fulfilled through special intellectual input device.
	Operation box for the handicapped	It is convenient for the wheelchair passengers and those who have vision problems.
 Monitor function	IC card control function	All (partial) landings can only input car commands through IC card after the authorization.
	Remote monitor	The remote monitor of lift can be fulfilled through modem and telephone, It is convenient for the makers and service units to know the travel conditions of every lift and take corresponding measures promptly.
	Remote control	Based on remote monitor, it is able to remote control some functions which not affect safety of lift's operation, For example, duplex or group control elevator independent operation.
	Camera function in the car	The camera is installed in the car to monitor the car conditions

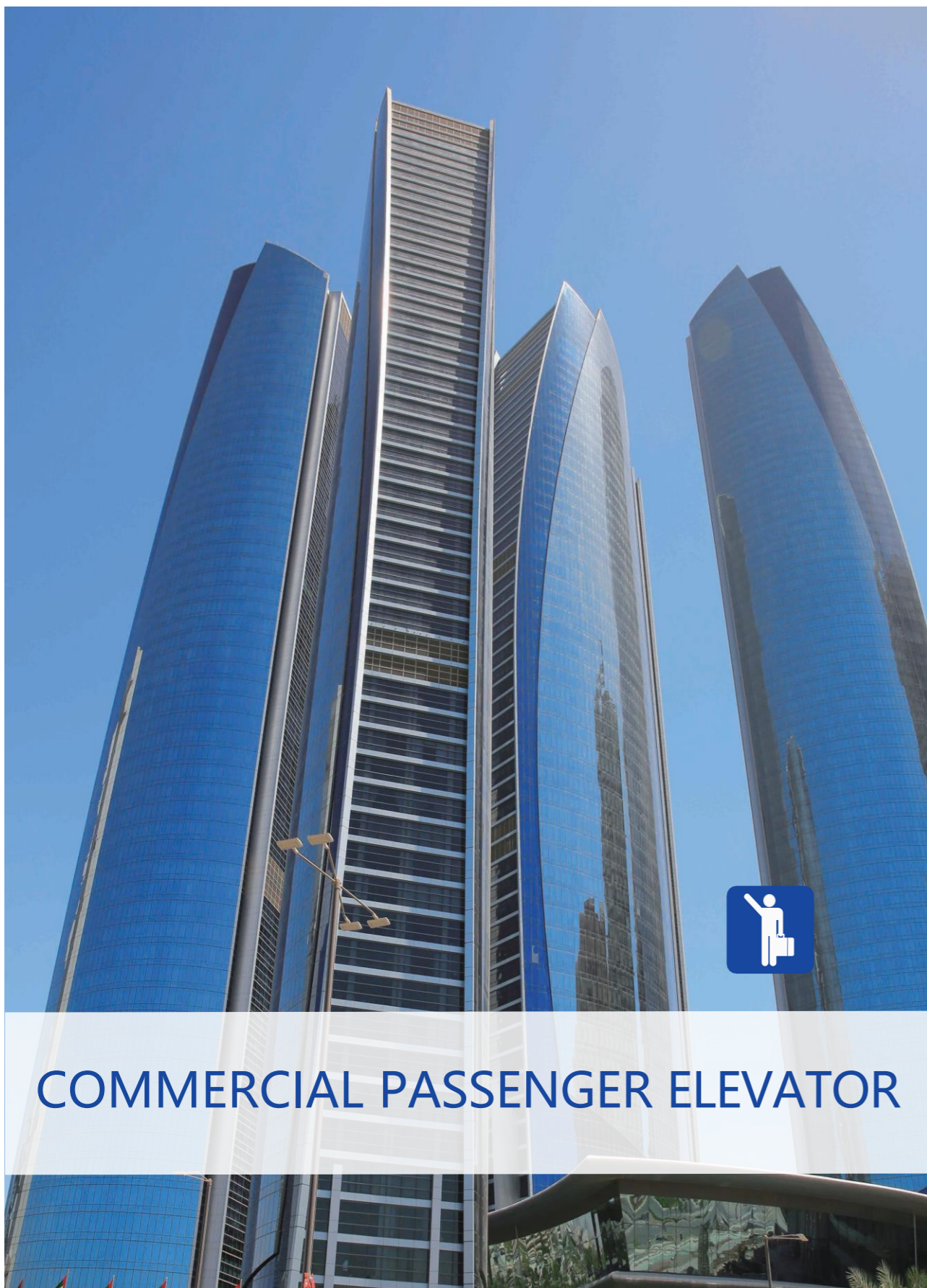

COMMERCIAL PASSENGER ELEVATOR

Commercial Passenger Elevator

Intelligent product with peak value

Schumacher commercial passenger elevator is a modern intelligent elevator that integrates intelligence, humanism and science. Widely used in office building, hotel, business center, hospital and other places with high passenger flow, it can bring convenience and enjoyment to your high-efficiency life.

The safe, accurate and guaranteed position control system

Advanced sensors on the motor rotor movement for high precision real time signal feedback, to achieve in a hoistway running car positioning achieve millimeter level precision, achieving almost no difference level. A reliable car displacement memory technology, to ensure that the elevator stops to open early peace layer security function.

Comfortable experience from car with clearance height of 2.8m

Car of the elevator is 60cm higher than traditional car, providing a wider and more comfortable carrying space.

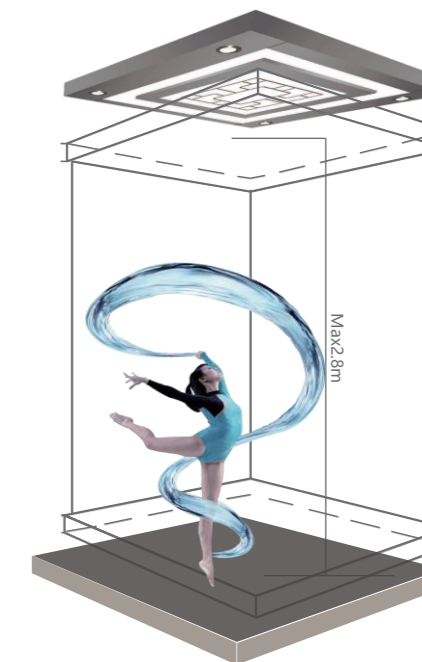

Passenger Elevator



LED high-efficiency green light source

This decreases power consumption of the elevator by 20%~35%.

Small Machine Room Passenger Elevator

Compact And Efficient, Stable And Reliable

To save space, expand the building larger space utilization rate, make the operation more flexible and reliable, make the building more elegant appearance, SCHUMACHER small machine room passenger elevator, the compact type permanent magnet synchronous gearless traction machine and the special design of the control cabinet, make room area is achieved and the well area is exactly the same.



Green environmental protection

Space-saving

Low Noise

Efficient and energy-saving

Stable and reliable

Machine Roomless Passenger Elevator

It reduces the building expense and saves the construction cost

In order to know the concept of environmental protection, energy saving, saving building area, improve the degree of freedom in design is the responsibility of the SCHUMACHER elevator without machine room, fully reflects the green spirit of humanity, the elevator needs only one independent well space, without room, with the same load weight level than conventional elevators, save construction area of 10%.



Reduce Energy Consumption Of The Elevator

Using the world's leading permanent magnet synchronous gearless machine, effectively reduce energy consumption, to achieve non-maintenance of elevator

Saving Up To 10% Area Of Construction

Schumacher machine roomless elevator further compression space, greatly improving the utilization of building space. Machine room and Shaft integrated design, to provide a great degree of freedom to the design of elevator and building.

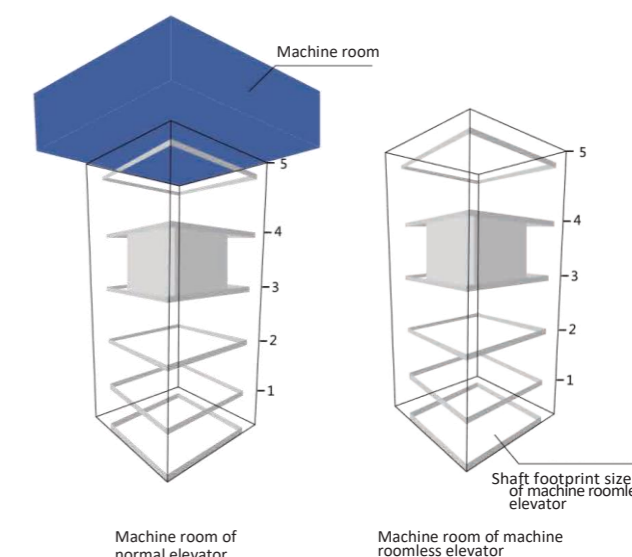

Passenger Elevator

Stretcher Elevator

Take the elevator rescue mission

Care for the health and safety of you and others, Schumacher together with you to achieve social responsibility. For the building design of elevator in case of emergency rescue, rescue use convenient. Elevator adopts special space design, suitable for placing a stretcher and beds, especially for the 120 and other rescue work. For the relief of the elevator to tailor the special function and high reliability of special master control system, emergency use, can quickly form a barrier free relief channel, between the free flow of each floor, the successful completion of the rescue work. Applicable to residential buildings, schools, office buildings, commercial buildings, hotels, shopping malls, entertainment and other public places.

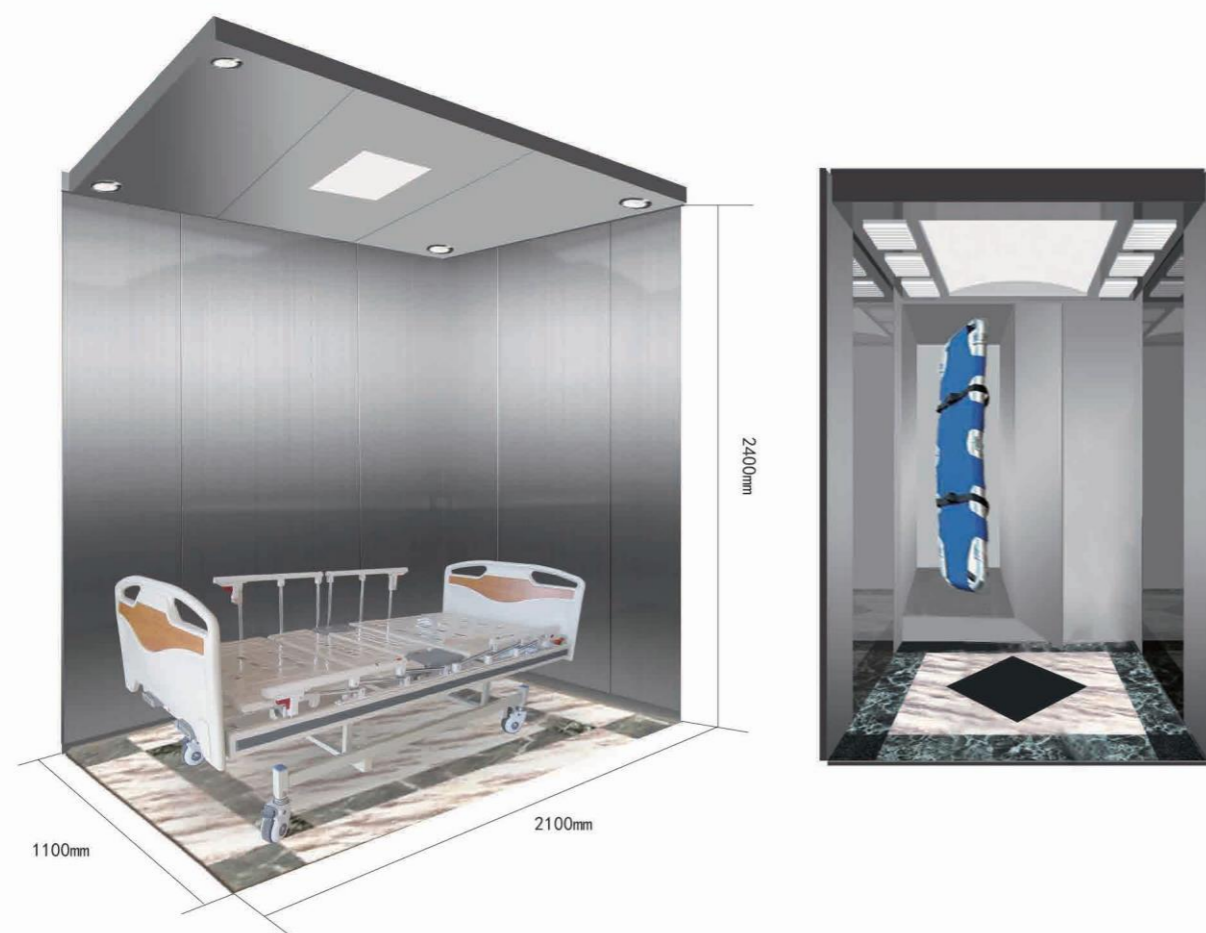

Convenient Stretcher, Protect The User Security

The car and lengthened, depth of up to 2100mm, can be placed in a medical stretcher vehicle, the intelligent wheelchair, a small cart stretcher bed, to meet the special requirements of users, to facilitate people's life.

Rescue system

Direct service rescue function:
Any floor start "rescue" function, can quickly reach the destination. "Rescue" function is activated, the elevator will no longer accept other call request, forming a fast dedicated direct channel, complete the delivery task in the short time, after the completion of the task, the system automatically resume normal use.

Emergency power supply system

For the completion of the rescue mission, the elevator can be equipped with rescue special emergency system, once the blackout, start the emergency power supply system, the nearest floor elevator door, completed the rescue work.

The design of compact well, save more for the user

Rescue elevator can design small room and no room, the design of compact well, no road and engine room, large space well convenient installation; different from medical elevator, medical elevator size mainly according to the status of the "bed", car of large scale, resulting in larger pool area and electrical energy. Waste of customers, for customers to save more.

The national edition of "residential design standards"

According to the people's Republic of China Ministry of housing and urban rural development, points out that the GB50096-2011 residential design standards issued jointly by the people's Republic of China State Administration of quality supervision, inspection and Quarantine Bureau, residential design standards, "residential 12 layers or more than 12 layers, each building set shall not be less than two lifts, one is specified elevator" can accommodate stretcher for emergency.

Car Decoration And Design

Standard configuration

Ceiling: Spraying Steel Plates, LED lights
Car walls: Short hairline stainless steel
Floor: PVC floor



Commercial Passenger Elevator Civil Figure

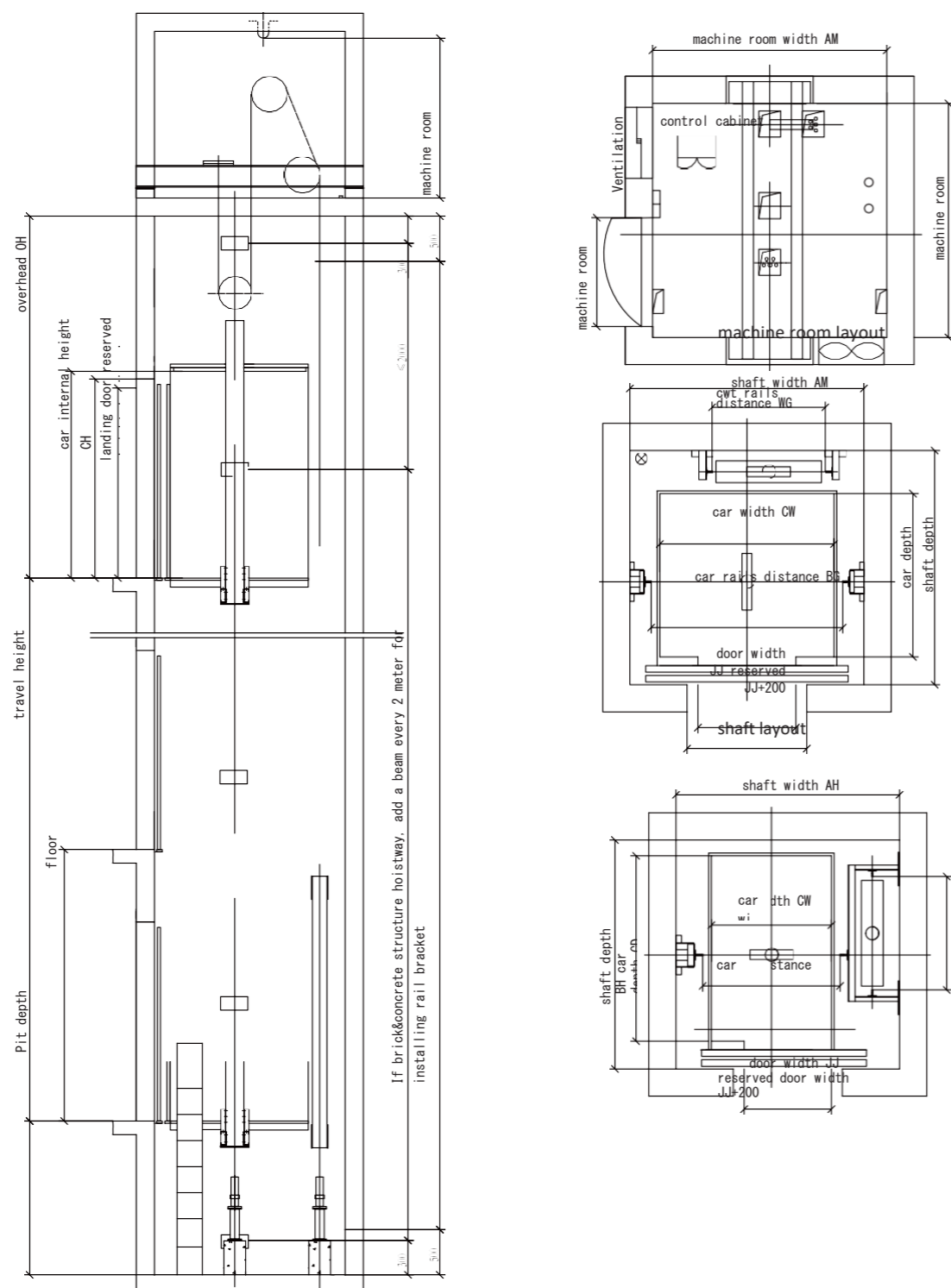

Standard passenger elevator Technical Data Sheet

Capacity KG	Speed m/s	Car dimension CW*CD*CH(mm)	Door size JJ*HH(mm)	Shaft size				Max floor	Max. travel height TH(m)
				shaft width* shaft depth AH*BH(mm)	overhead OH(mm)	pit depth PD(mm)	Min floor space mm		
630 (8Persons)	1.0	1400*1100*2400	800*2100	1950*1750	4200	140	270	16	60
	1.5				0	145		24	75
	1.75				0	150		30	90
800 (10Persons)	1.0	1400*1350*2400	800*2100	1950*2000	4200	140	270	16	60
	1.5				0	145		24	75
	1.75				0	150		30	90
	2				0	180		35	105
	2.5				0	200		40	120
	3				0	350		50	150
1000 (13Persons)	1.0	1600*1500*2400	900*2100	2150*2150	4250	140	270	16	60
	1.5				0	145		24	75
	1.75				0	150		30	90
	2				0	180		35	105
	2.5				0	200		40	120
	3				0	350		50	150
1250 (16Persons)	1.0	1800*1500*2400	1100*2100	2400*2200	4250	140	270	16	60
	1.5				0	145		24	75
	1.75				0	160		30	90
	2				0	180		35	105
	2.5				0	200		40	120
	3				0	350		50	150
1600 (21Persons)	1.0	1900*1800*2400	1100*2100	2500*2500	4250	140	270	16	60
	1.5				0	145		24	75
	1.75				0	160		30	90
	2				0	180		35	105



4800	2000	40	120
5500	3500	50	150

Note: the above for the civil diagram,detailed dimensions see

Shaft& machine room vertical section

standard machine room stretcher elevator

civil details

Capacity KG	Speed m/s	Car dimension CW*CD*CH(mm)	Door size JJ*HH(mm)	Shaft size			Min floor space mm	Max floor	Max. travel height TH(m)
				shaft width* shaft depth AH*BH(mm)	overhead OH(mm)	pit depth PD(mm)			
800	1.5	1100*1700*240	800*2100	2000*2100	4200	1400	2700	24	75
					4250	1450		30	90
					4300	1500		16	60
1000	1.5	1100*2100*240	800*2100	2000*2500	4400	1450	270	24	75

construction plans,specific to the technical department to provide construction drawings.

Standard Small Machine Room Stretcher Elevator Technical Data Sheet



Machine Roomless Passenger Elevator Civil Figure

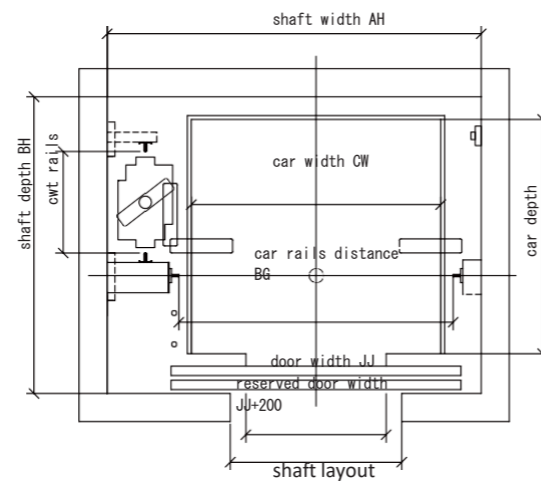
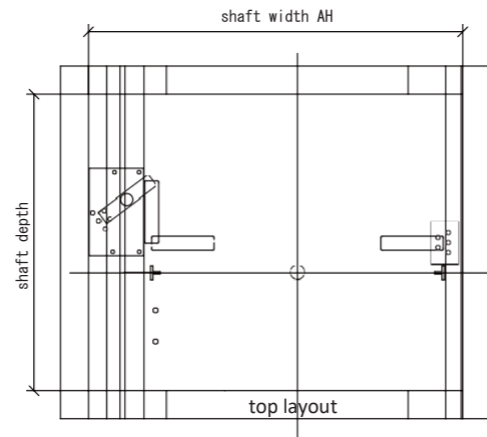
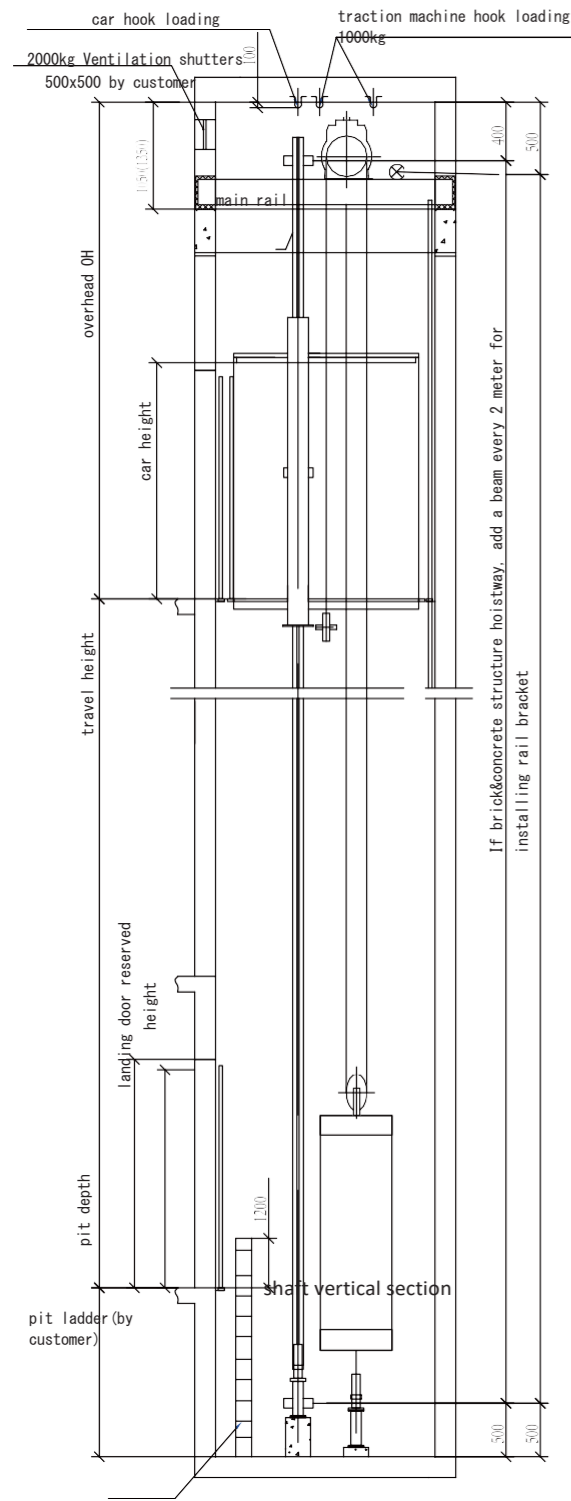

Standard machine roomless passenger elevator Technical Data Sheet

Capacity KG	Speed m/s	Car dimension CW*CD*CH(mm)	Door size JJ*HH(mm)	Shaft size			Min floor space mm	Max floor	Max travel height TH(m)
				shaft width* shaft depth AH*BH(mm)	overhead OH(mm)	pit depth PD(mm)			
630 (8Persons)	1.0	1400*1100*2400	800*2100	2200*1600	4100	1500	2700	16	60
	1.5				4200	1600		24	75
	1.75				4250	1700		30	90
800 (10Persons)	1.0	1400*1350*2400	800*2100	2200*1800	4100	1500	2700	16	60
	1.5				4200	1600		24	75
	1.75				4250	1700		30	90
1000 (13Persons)	1.0	1600*1500*2400	900*2100	2400*1900	4100	1500	2700	16	60
	1.5				4200	1600		24	75
	1.75				4250	1700		30	90
1250 (16Persons)	1.0	1500*1500*2400	1000*2100	2750*2000	4400	1500	2700	16	60
	1.5				4500	1600		24	75
	1.75				4600	1700		30	90

Note: the above for the civil diagram, detailed dimensions see construction plans specific to the technical department to provide on site.

Standard Machine Room Less Stretcher Elevator Technical Data Sheet

Capacity KG	Speed m/s	Car dimension CW*CD*CH(mm)	Door size JJ*HH(mm)	Shaft size			Min floor space mm	Max floor	Max travel height TH(m)
				shaft width* shaft depth AH*BH(mm)	overhead OH(mm)	pit depth PD(mm)			
800	1.0	1100*1700*2400	800*2100	2000*2100	4200	1400	2700	16	60
	1.5				4250	1450		24	75
	1.75				4300	1500		30	90
1000	1.0	1100*2100*2400	800*2100	2000*2500	4300	1400	2700	16	60
	1.5				4400	1450		24	75
	1.75				4450	1500		30	90

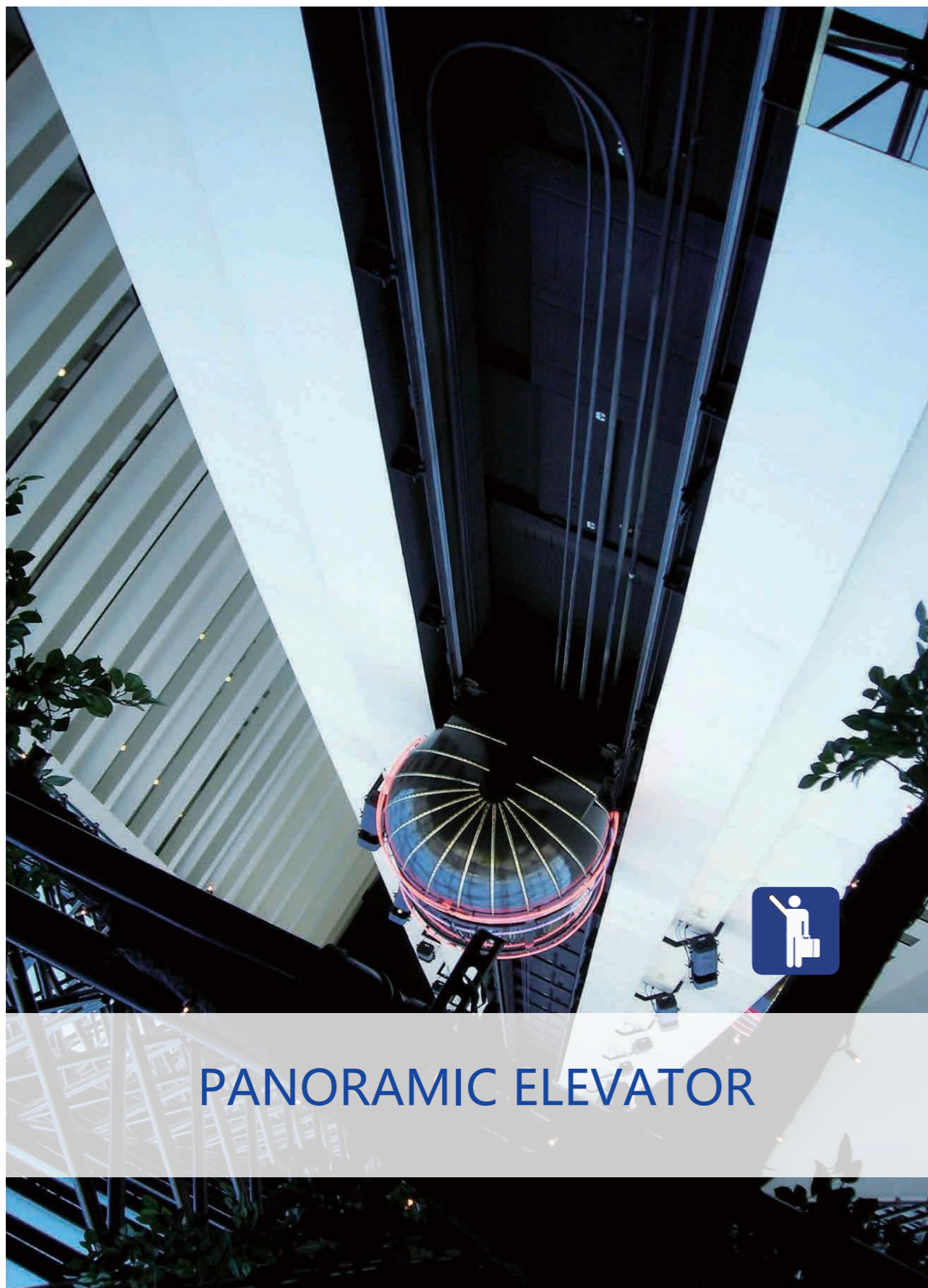

PANORAMIC ELEVATOR

Car Decoration And Design



SMK-G001

Cover: steel coating
 Tourism wall: Laminated glass
 Decorative top: multilayer reflectors lighting design complemented by four weeks waist translucent hole and organic lamp post, the soft light rich three-dimensional sense of depth
 Car Wall: Laminated glass
 Handrail: Stainless steel tube
 Floor: PVC Floor



SMK-G004

Cover: steel coating
 Tourism wall: Laminated glass
 Decorative top: multilayer reflectors lighting design complemented by four sides waist translucent hole and organic lamp post
 Car Wall: Laminated glass
 Handrail: Stainless steel tube
 Floor: PVC Floor



SMK-G002

Cover: Steel plate spraying decorative lights
 Tourism wall: Laminated glass
 Decorative top: on the mirror surface stainless steel plate combined with the car wall down light golden shine, the middle part is arch white translucent panels of soft illumination
 Car Wall: Hairline stainless steel plate
 Handrail: Stainless steel tube
 Floor: PVC Floor



SMK-G005

Cover: Steel plate spraying decorative lights
 Tourism wall: Laminated glass
 Decorative top: on the mirror surface stainless steel plate combined with the car wall down light golden shine, the middle part is arch white translucent panels of soft illumination
 Car Wall: Hairline stainless steel plate
 Handrail: Stainless steel tube
 Floor: PVC Floor



SMK-G003

Cover: Acrylic semicircular crown and plate coating and stainless steel panels and decorative lights
 Tourism wall: three laminated glass
 Decorative top: white ceiling light plus downlights
 Car Wall: Hairline stainless steel plate
 Handrail: Stainless steel tube
 Floor: PVC Floor



SMK-G006

Cover: Acrylic semicircular crown and plate coating and stainless steel panels and decorative lights
 Tourism wall: three laminated glass
 Decorative top: white ceiling light plus downlights
 Car Wall: Hairline stainless steel plate
 Handrail: Stainless steel tube
 Floor: PVC Floor

Panoramic Elevator Civil Figure

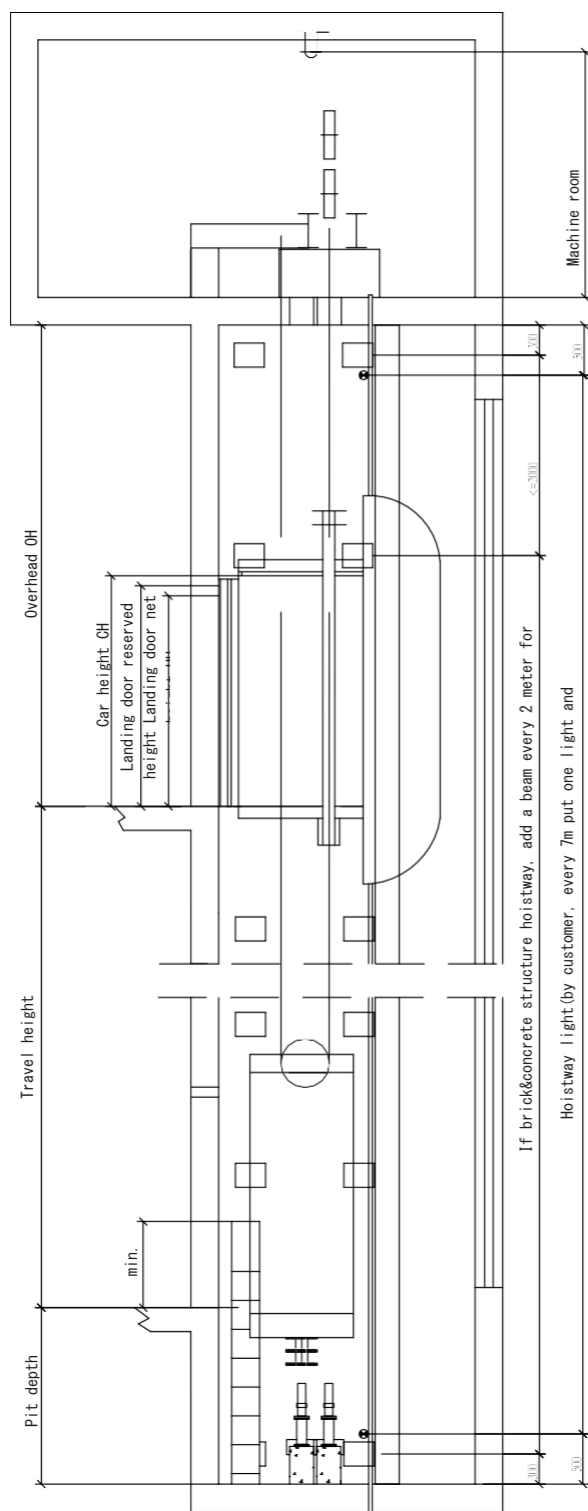

Shaft & machine room vertical section

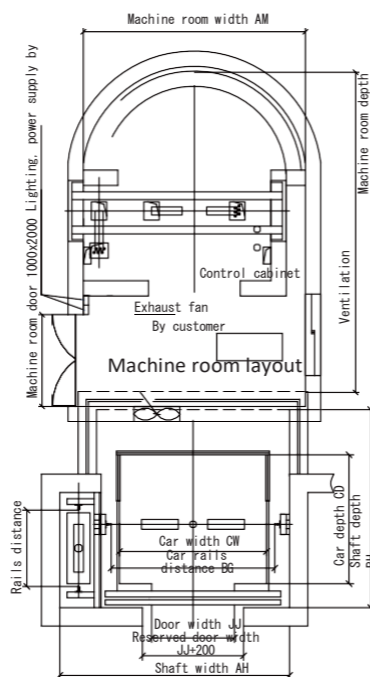

Machine room layout

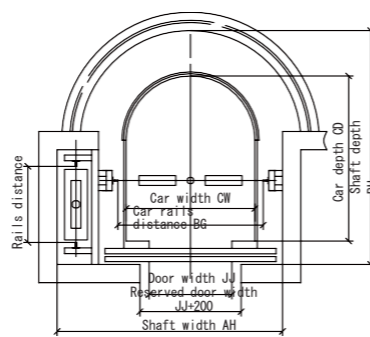

Shaft layout (square)

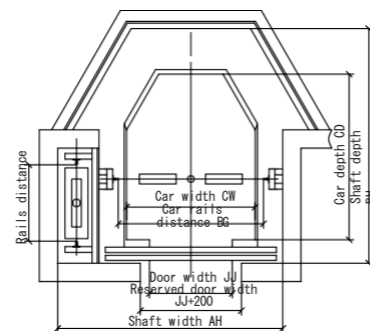

Shaft layout (Semi-circular)

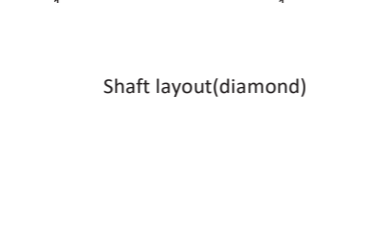

Shaft layout (diamond)

Capacity KG	Speed m/s	Car dimension CW*CD*CH(mm)	Door opening	Shaft size				Max floor	Max travel height TH(m)
				shaft width* shaft depth AH*BH(mm)	overhead OH(mm)	pit depth PD(mm)	Min floor space mm		
800 (10Persons)	1.0	1350*1400*2400	800*2100	2250*1900	4400	1800	2700	16	60
	1.5				4500	1900		24	75
	1.75				4600	2000		30	90
1000 (13Persons)	1.0	1600*1500*2400	900*2100	2500*2000	4400	1800	2700	16	60
	1.5				4500	1900		24	75
	1.75				4600	2000		30	90
1250 (16Persons)	1.0	1800*1500*2400	900*2100	2700*2000	4400	1800	2700	16	60
	1.5				4500	1900		24	75
	1.75				4600	2000		30	90
1600 (21Persons)	1.0	1700*2150*2400	1000*2100	2750*2700	4400	1800	2700	16	60
	1.5				4500	1900		24	75
	1.75				4600	2000		30	90

Standard semi-circular panoramic elevator with machine room Technical Data Sheet

Panoramic Elevator

Machine Roomless Panoramic Elevator Civil Figure

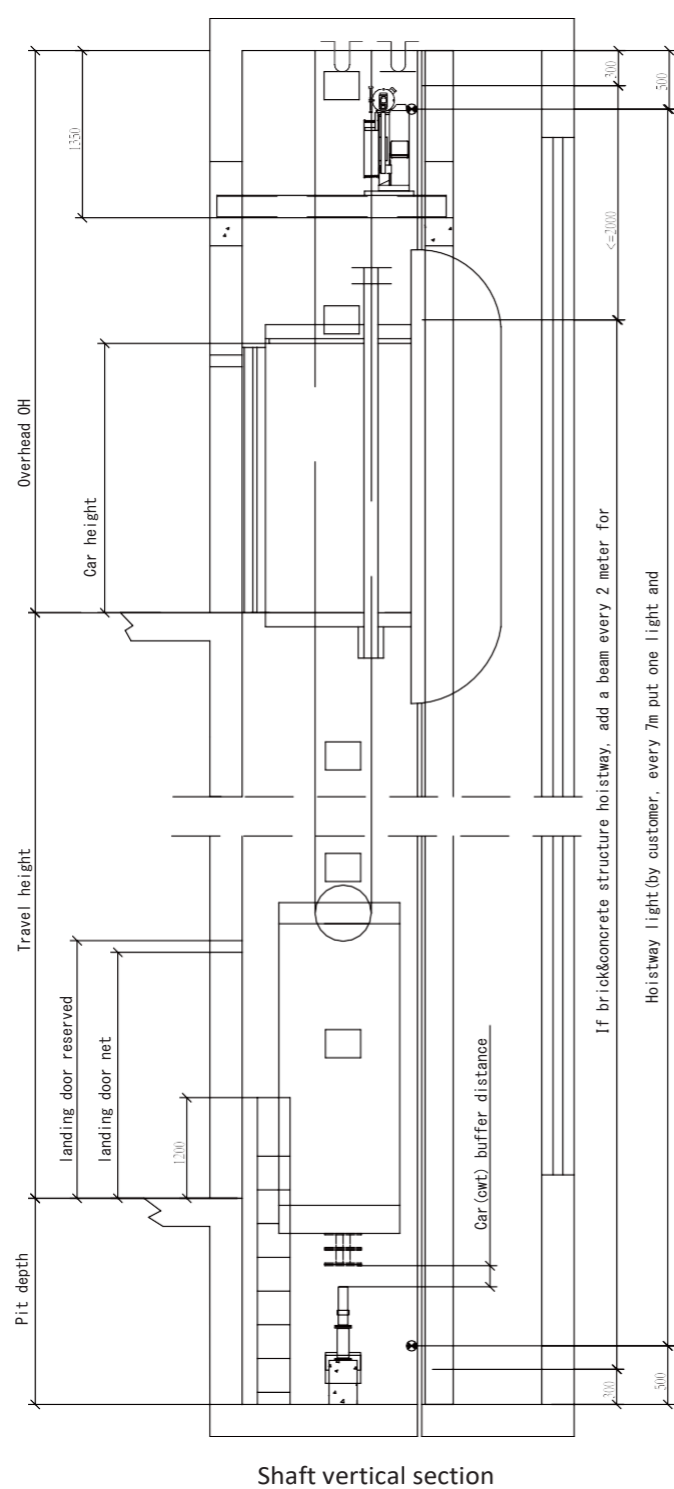

Shaft vertical section

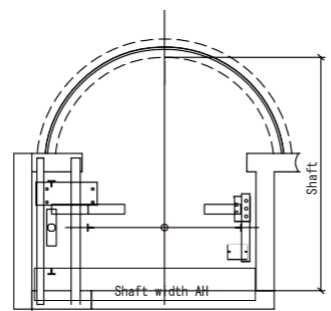

Top Layout

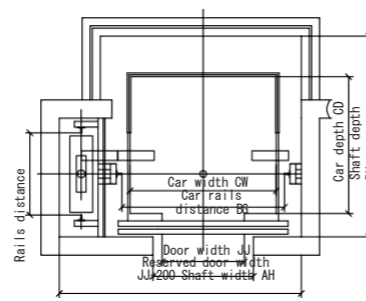

Shaft layout (square)

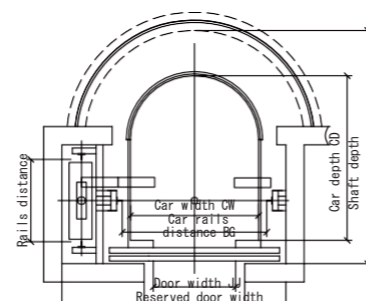

Shaft layout (Semi-circular)

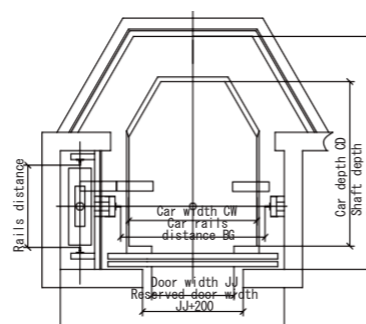

Shaft layout (diamond)

Standard square machine roomless sightseeing elevator Technical Data Sheet

Capacity KG	Speed m/s	Car dimension CW*CD*CH(mm)	Door openin g	Shaft size				Max floor	Max. travel height TH(m)
				shaft width* shaft depth AH*BH(mm)	overhead OH(mm)	pit depth PD(mm)	Min floor space mm		
800 (10Persons)	1.0	1250*1500*2400	800*2100	2250*2000	4400	1800	2700	16	60
	1.5				4500	1900		24	75
	1.75				4600	2000		30	90
1000 (13Persons)	1.0	1600*1500*2400	900*2100	2650*2000	4400	1800	2700	16	60
	1.5				4500	1900		24	75
	1.75				4600	2000		30	90
1250 (16Persons)	1.0	1800*1500*2400	900*2100	2850*2000	4600	1800	2700	16	60
	1.5				4700	1900		24	75
	1.75				4800	2000		30	90
1600 (21Persons)	1.0	1900*1800*2400	1100*2100	2950*2300	4600	1800	2700	16	60
	1.5				4700	1900		24	75
	1.75				4800	2000		30	90

Capacity KG	Speed m/s	Car dimension CW*CD*CH(mm)	Door openin g	Shaft size				Max floor	Max. travel height TH(m)
				shaft width* shaft depth AH*BH(mm)	overhead OH(mm)	pit depth PD(mm)	Min floor space mm		
800 (10Person s)	1.0	1200*1700*2400	800*2100	2250*2250	4400	1800	2700	16	60
	1.5				4500	1900		24	75
	1.75				4600	2000		30	90
1000 (13Person s)	1.0	1400*1800*2400	900*2100	2450*2350	4400	1800	2700	16	60
	1.5				4500	1900		24	75
	1.75				4600	2000		30	90
1250 (16Person s)	1.0	1500*2000*2400	900*2100	2550*2550	4600	1800	2700	16	60
	1.5				4700	1900		24	75
	1.75				4800	2000		30	90
1600 (21Person s)	1.0	1700*2150*2400	1000*2100	2750*2700	4600	1800	2700	16	60
	1.5				4700	1900		24	75
	1.75				4800	2000		30	90

Panoramic Elevator

Hospital Elevator

Fulfill Equal Carrying In A Harmonious Space

Schumacher bed elevators not only transport passengers, but also have special and strict requirements for special function and performance of the elevator. Schumacher bed elevators precisely control the speed of the elevator, run smoothly and comfortable. Schumacher series hospital elevators emphasize human-oriented design to fully optimize the car structure, satisfy customer requirements. Give passengers a serene, elegant space.

Schumacher series hospital elevator has its unique design concept, creativity and harmony of the hospital environment, clean and bright space give passengers a comfortable environment for the patient but also adds a bit of confidence back to health.



Group control management system, intelligent dispatching

Schumacher bed elevator, centralized control of multiple elevator, system within all the time to calculate which elevator is the most rapid economic and reasonable to meet response signal, with the fastest speed, maximum efficiency to provide doctors and patients dispersion elevator. Increase elevator operational efficiency, reduce patient waiting time to adapt to the special needs of the hospital.

Anti-magnetic interference, better adapted to the use of modern medicine

3G mobile communication is perfect combined with internet, real-time acquisition computer board, inverter data, wireless remote transmission, to achieve Internet remote monitoring.

Special functions for the handicapped fulfill equal carrying in a harmonious space

Schumacher bed elevator efforts to create equality accessible space for all people, will incorporate the needs of disable people into the elevator design concept, not only mark Braille on the button, but also the control box inside the car to take a cross-loaded manner, 1 meter from the car bottom, very convenient for disable people, while not affect the ordinary passengers.

Car Decoration And Design



SMK-Y101



SMK-BC001



SMK-BC002

Standard Configuration

Ceiling : stainless steel with ivory euphotic plate lighting, LED lights

Car walls : Short hairline stainless steel, Mirror Floor : PVC floor

Bed Elevator Civil Figure

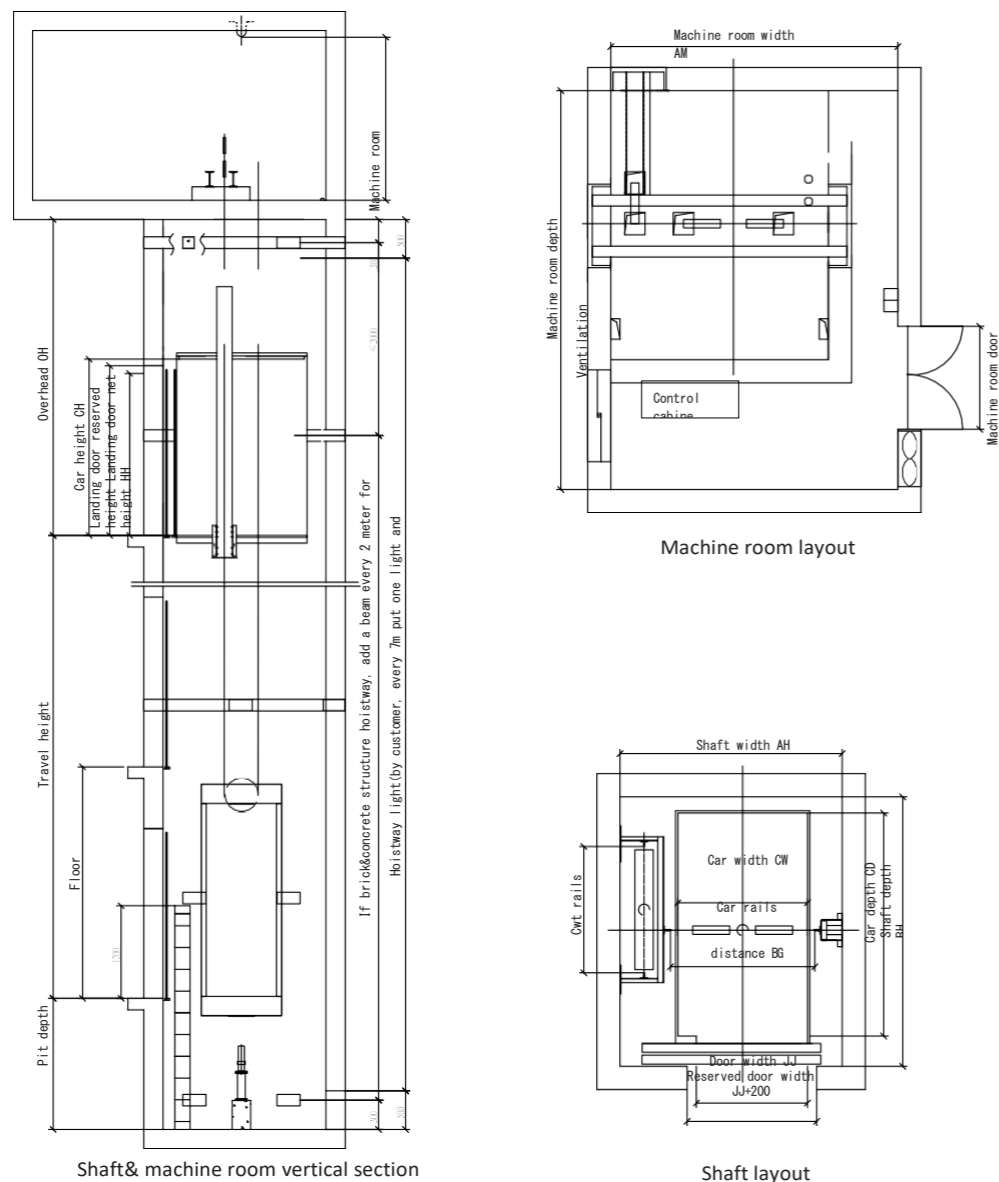

Machine Roomless Bed Elevator Civil Figure

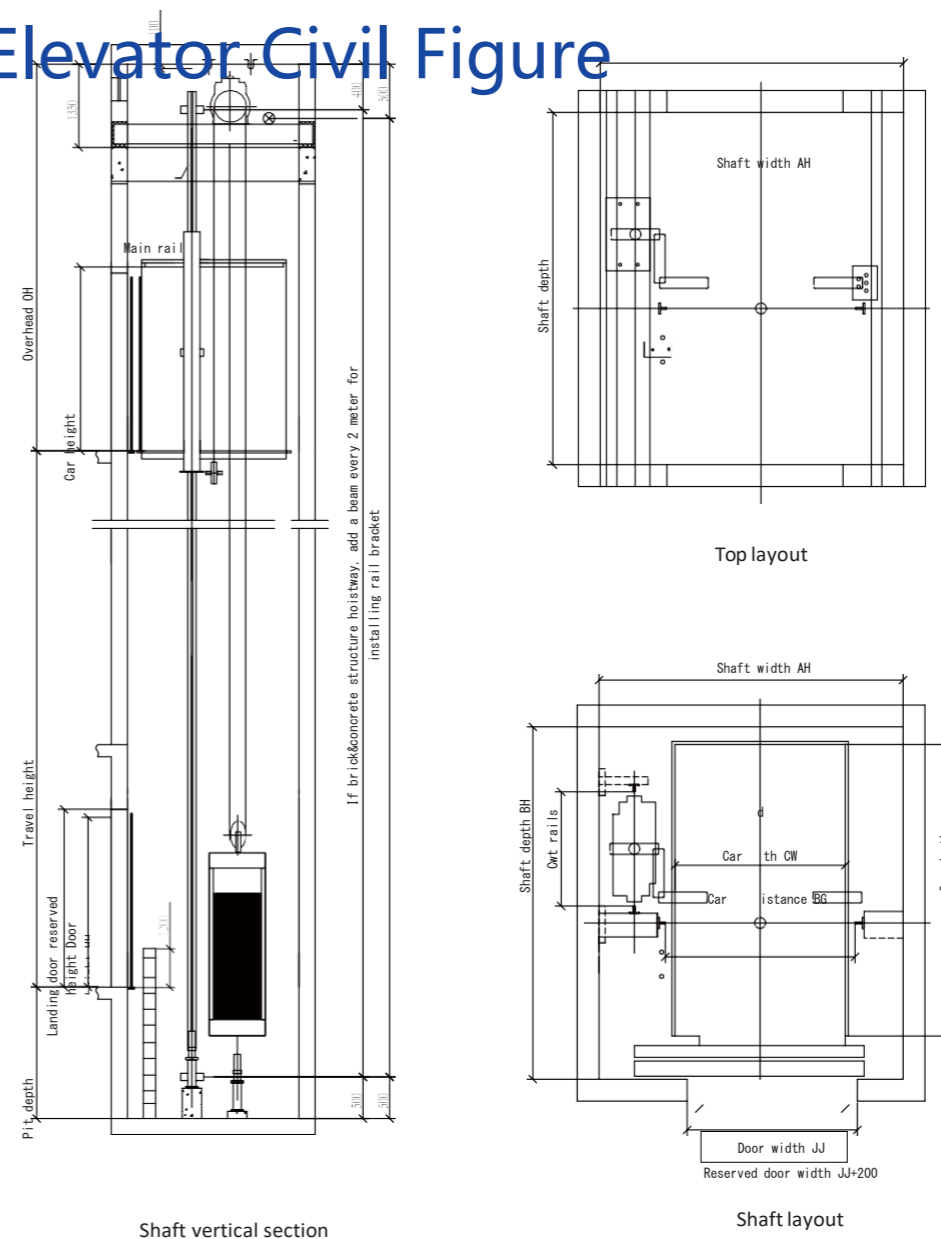

Standard machine room hospital elevator Technical Data Sheet

Capacity KG	Speed m/s	Car dimension CW*CD*CH(mm)	Door size JJ*HH(mm)	Shaft size			Max floor	Max travel height TH(m)	
				shaft width* shaft depth AH*BH(mm)	overhead OH(mm)	pit depth PD(mm)			
1600 (21Persons)	1.0	1400*2400*2400	1200*2100	2350*2900	4250	1400	2700	16	60
	1.5				4400	1450		24	75

Note: the above for the civil diagram, detailed dimensions see construction plans, specific to the technical department to provide construction drawings.

Standard machine roomless hospital elevator Technical Data Sheet

Capacity KG	Speed m/s	Car dimension CW*CD*CH(mm)	Door size JJ*HH(mm)	Shaft size			Max floor	Max travel height TH(m)	
				shaft width* shaft depth AH*BH(mm)	overhead OH(mm)	pit depth PD(mm)			
1600 (21Persons)	1.0	1400*2400*2400	1200*2100	2350*2900	4400	1500	2700	16	60
	1.5				4500	1600		24	75

Note: the above for the civil diagram, detailed dimensions see construction plans, specific to the technical department to provide construction drawings.

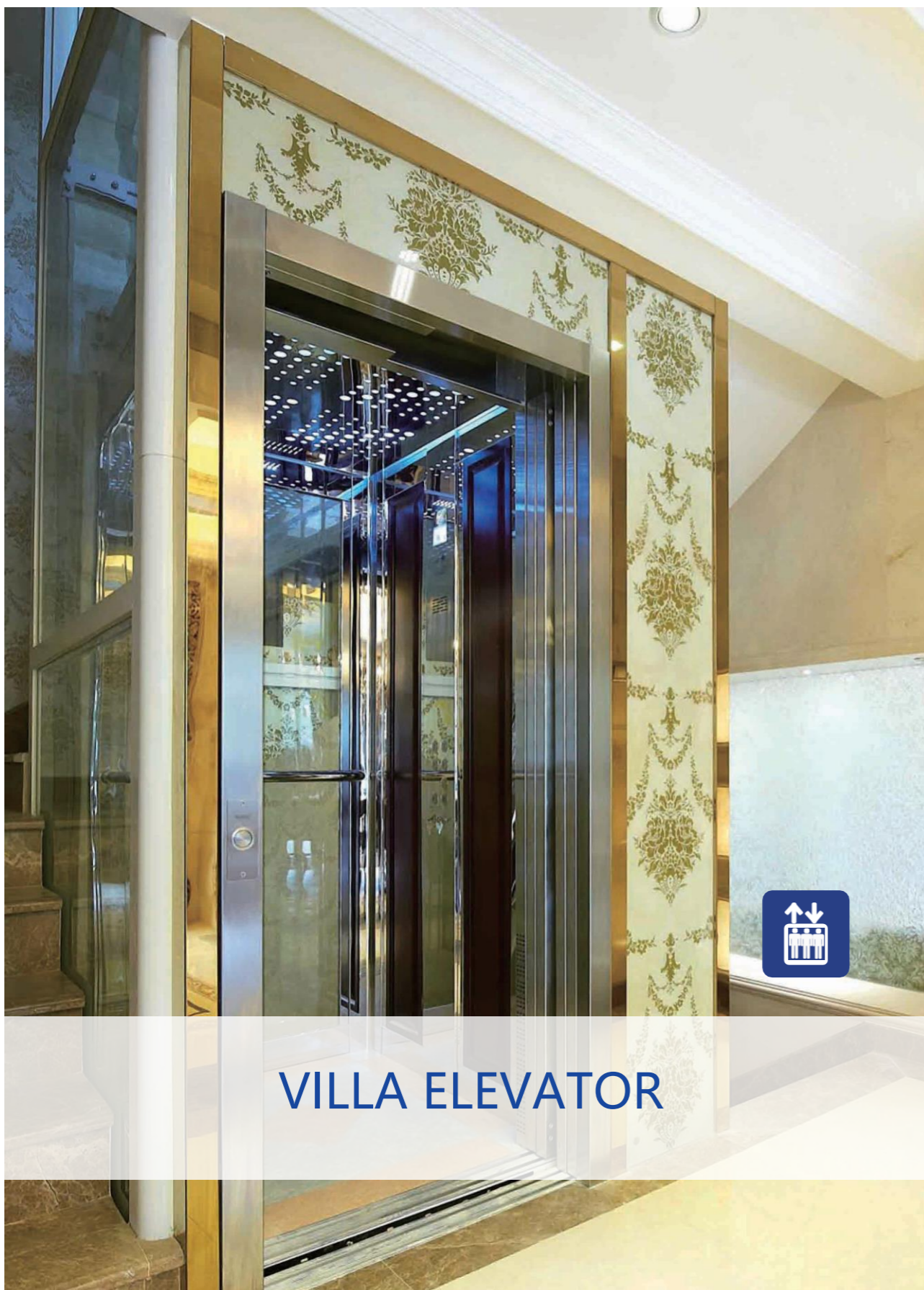

VILLA ELEVATOR

Comfort make you to enjoy home life

Dedicated inverter system, precise control the running of the elevators, comprehensive approach to improve your experience, pre-torque function, according to the load information provided by the sensor, automatically adjusts the starting torque of the elevator, make the elevator to start more comfortable. Gearless sealed bearings require no lubrication, the complete elimination of oil pollution, but also eliminates the noise when gearbox run, bring you beautiful home environment.

New appliances, bring you new life

Whether Schumacher villa elevator is installed indoors or outdoors, no need special shaft, no special pit, no dedicated room, even without a lot of civil construction, easy like any home appliances placed in your home, without any space restrictions. Just need extremely low maintenance costs.

Villa Lift Technology Advantage

The specialty of traction villa lift

- ◎ without traditional machine room: save construction costs
- ◎ without traditional big depth pit: H = 300-700
- ◎ Traction ratio 1: 1 or 2:1 Villa elevator specially designed structure system
- ◎ VVVF drive technology: computer control panels, smooth and comfortable
- ◎ Motor: Household special elevator hoisting machine
- ◎ Door operator: belt drive, smooth and low noise



Product range

Independent villas / private mansions / Newhouse / Townhouse / Private accommodation / Private installation duplex Apartments

Alternative Door Styles, Different Choice

Varies of kinds door open style provided for you, you can choose any one of them as per your needs for your building requirement.

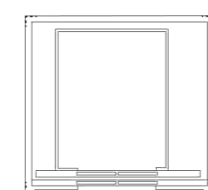

中分式
Center-opening

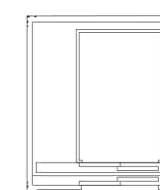

Side-opening



Manually operated door

Efficient vector elevator inverter

With high-performance current vector control and cosine encoders to achieve the torque compensation function, make the elevator more comfortable; elevator maintenance more simple and convenient; automatic torque boost function can easily cope with various elevator loads.



Smooth running

With the characteristic of high precision manufacturing inorganic gear operation, closed-loop VVVF drive, start-up and stop smoothly and comfortably.

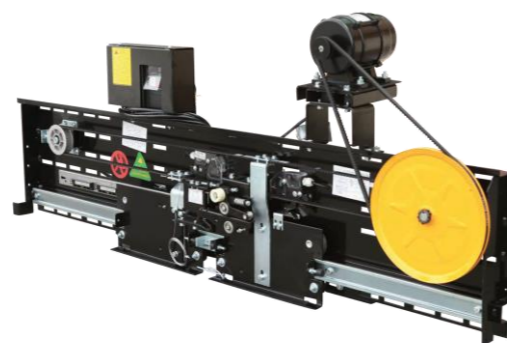

Intelligent Control System

Professional designed 32-bit main computer board, using CAN bus serial communication technology, so that it can accurately and reliably to control the operation of the elevator, diagnose any faults that elevator may occur every moment, and make the appropriate security measures and alert.

Top Grade Door Operator System

Use advanced VVVF door operator system, make sure the door open and close smoothly, reduce noise



Rope Broken Switch

MRL lift was designed with a rope broken switch is provided to stop lift and protect passengers in case of the suspension rope broken



Gantry type car frame, more stable equilibrium

Elevator car apply gantry frame structure, which can increase the stability and comfort of the car, but also to ensure the elevator running in a balanced state, reduce system friction and increase service life of elevator components.

Personalized Optional Highlight You Honorable

Emergency leveling system

To prevent accidental power cut off, lift apply ARD emergency leveling power, ensures that after a mains power outage, there is still enough power to make the elevator run security to take the passengers to nearest landing.



IC card intelligent floor selector

In order for the elevator to be you and your family's tools, we can provide IC card elevator intelligent control functions, you can use your access card or special IC card provided by us to use the lift, in addition, the lift will not in response to any other way of layer selection.

One-touch dialing

When child or elderly parents use home lift, safe ride has become the core issue of our primary consideration, machine roomless villa elevator set the automatic dial-up telephone on control panel. When lifts close or other emergency, click the alarm, the saved emergency number will be automatically appropriated, maximum guarantee the safety of the elderly and children, 2-3 phone, which are saved in the auto-dial telephone, will automatically dial a call for help in turn, maximum guarantee the safety of the elderly and children.

Personalized Optional Highlight You Honorable

Fingerprint intelligent recognition

On the basis of IC card intelligent routing layer, we can also provide a fingerprint identification system to replace the card, you can manipulate the elevator through the fingerprint input, without your authorization, any other way will not be able to use your elevator, really interpretation of the concept of exclusive



Remote monitoring

Based on the perfect combination of 3G mobile communications technology and INTERNET network, through data acquisition module in the elevator control cabinet, real-time acquisition operational data of computer board and inverter, wireless remote transmission to the control center, to achieve all time surveillance, if elevator failure, within a few seconds, control center can achieve fault alarm information preservation, fault diagnosis and dispatching maintenance.

Steelwork Shaft

Using steelwork shaft, users can greatly facilitate civil construction, reduce civil footprint, save construction costs, and provide a platform for user fitting, easy to meet the individual needs of users.

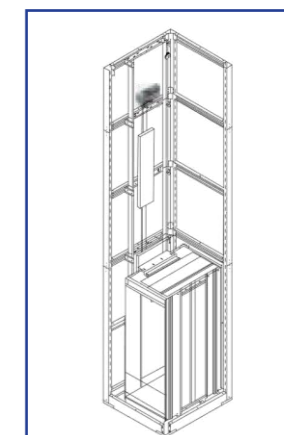

Warm And Elegant Car Decoration

Fine, Popular And Exquisite Designs



SMK-J001

Ceiling: wood veneer frame, middle clinquant, surrounded downlights
Car wall: center wood veneer, side mirror stainless steel
Floor: Marble parquet



SMK-J004

Ceiling: wood veneer frame, middle clinquant, surrounded downlights
Car wall: side mirror stainless steel, center photo by customer
Floor: Marble parquet



SMK-J002

Ceiling: Rose gold stainless steel frame + punching plates
Car wall: three centers rose gold mirror etching, auxiliary plate rose gold hairline plate
Flooring: Marble parquet



SMK-J005

Ceiling: wood veneer frame, intermediate laser cutting process with marble translucent sheet
Car wall: three sides center wood finishes styling wrapped around a mirror etching titanium,
Floor: Marble parquet



SMK-J003

Ceiling: wood veneer shape, center clinquant, lamp lighting
Car wall: three side center wood veneer, auxiliary plate rose gold mirror plate
Floor: Marble parquet



SMK-J006

Ceiling: wood finishes modeling, hidden lights, lamp lighting
Car wall: back side wood finishes with stainless steel bar, both sides intermediate mirror stainless steel, auxiliary plate leather
Floor: Marble parquet

Standard Villa Elevator Civil Figure

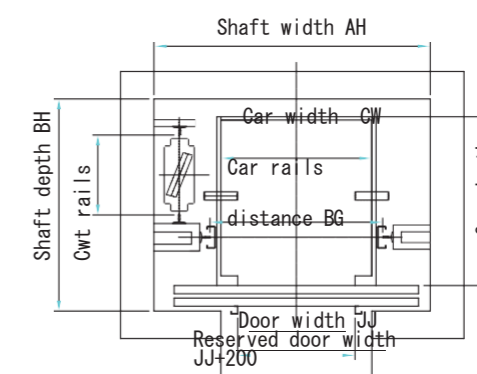
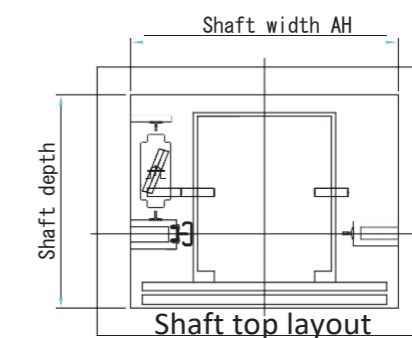
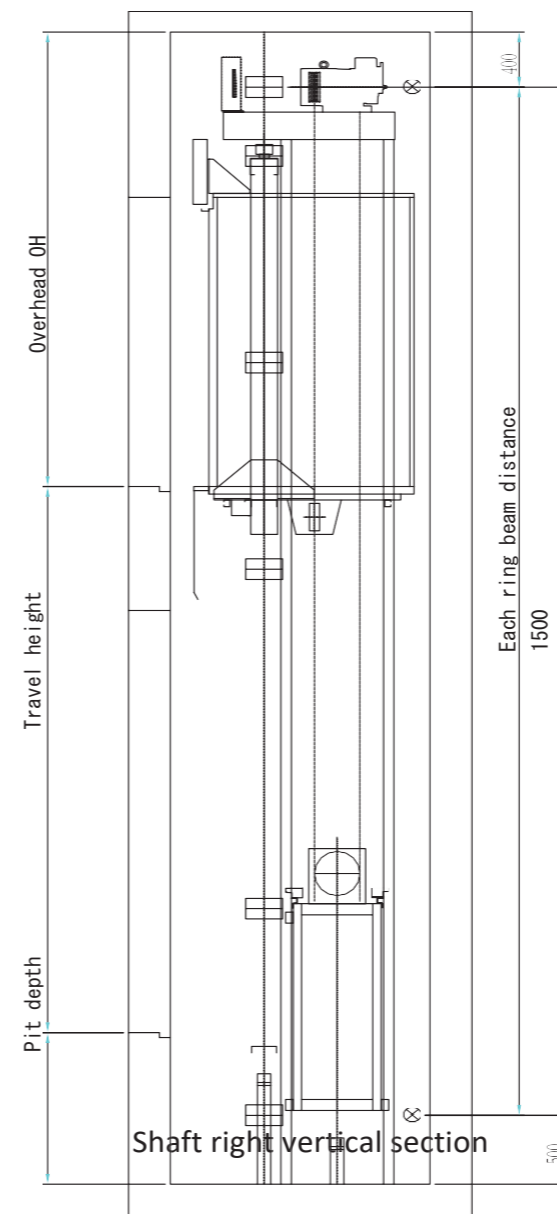

Shaft layout

Standard Villa Elevator Technical Data Sheet

Capacity KG	Speed m/s	Door opening	Car dimension CW*CD*CH(mm)	Door size JJ*HH(mm)	Shaft size			Max. travel height TH(m)
					shaft width* shaft depth AH*BH(mm)	overhead OH(mm)	pit depth PD(mm)	
250	0.4	Center opening	900*1100*2200	700*2000	1650*1450	3300	800	12
320	0.4	Center opening	900*1200*2200	700*2000	1650*1500	3300	800	12
400	0.4	Center opening	1000*1250*2200	700*2000	1700*1550	3300	800	12

Note: The drawings and specifications shown on sample are only for your reference, any order please confirm with Schumacher company.

Human-machine Interface

Human-machine Interface



SMK-C101
hairline(standard)



SMK-W106
Hairline thin
wall-mounted (standard)
(optional mirror, titanium)



SMK-C102
mirror(optional)



SMK-W104-16
Mirror wall-mounted
(optional)

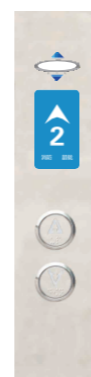

SMK-W103-16
Mirror embedded
(optional)



SMK-C103
Integrated



SMK-YJ06 (Standard)

7" Colorful LCD
Display size: 155x87
Maximum dimensions: 188x113x27.7



SMK-YJ08 (Matching)

10" Colorful LCD
Display size: 197.5x148.5
Maximum dimensions: 250.3x193.6x32



SMK-W102-16
Hairline



SMK-W108
Titanium



SMK-W107



SMK-D105



SMK-H105

Remark

1. Standard material is stainless steel hairline
2. Optional material is mirror stainless steel or titanium stainless steel
3. Optional base plate is circular or elliptical

Vertical elevator decoration

The pictures are plotted by computer and are likely somewhat different from the actual products.

Decorative Of Elevator Car (Option)

Landing door (option)



SMK-TM001

steel coated (other landing door standard)



SMK-T002

hairline stainless steel(1st landing door standard)



SMK-TM003

mirror, etching, hairline (optional)



SMK-TM003-16

mirror, etching, hairline (optional)

Ceiling (Option)

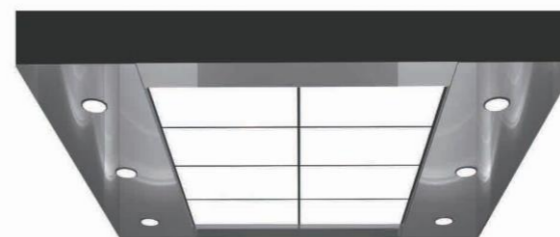

SMK-D002

Mirror stainless steel frame, the middle of the line image translucent panels



SMK-D003-16

Titanium or stainless steel frame mirror plus lamp, translucent panels



SMK-D004-16

Mirror stainless steel frame plus lamp, organic pillar



SMK-D005

Central image vault, flanked by soft lighting design complemented by a stainless steel plate



SMK-D001

Mirror stainless steel frame, square downlights, intermediate translucent panels



SMK-D008

Two parallel white organic light-transmissive plate, plus intermediate downlights soft lighting design

More elevator decoration, please refer to schumacher's elevator decoration manual.

Decorative Of Elevator Car (Option)

PVC Floor



SMK-01-16
(Standard)



SMK-02-16
(Standard)



SMK-03-16
(Standard)



SMK-04-16
(Standard)



SMK-05-16
(Standard)



SMK-06-16
(Standard)



SMK-07-16
(Optional)



SMK-08-16
(Optional)



SMK-09-16
(Optional)

Plate spray card



SMK-S010
Cream-colored

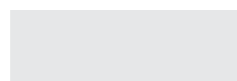

SMK-S020
Light gray



SMK-S030
Aurora Silver



SMK-S040
Apple green

Handrail (option)



HL-301F Short grain matt stainless steel



HL-301TF Titanium matt short-grain single tube



HL-303J Mirror stainless steel tube triple combination



HL-303TJ Titanium stainless steel tube triple combination



HL-308 Stainless steel tube mirror, titanium composition



HL-309TM Wood in combination with titanium



HL-303TJ Titanium stainless steel tube triple combination



HL-310TM Roundwood



HL-313F Stainless steel short grain, circular head



HL-313TF Stainless steel titanium short-grain, circular head



VEHICLE & FREIGHT ELEVATOR

Advanced Technology

Permanent magnetic synchronous gearless traction machine

Permanent magnet synchronous traction technology is a new generation of low-carbon energy saving elevator core technology researched by Schumacher and motor manufacturer. Compared with traditional technology, this technology is with low-carbon energy, less space, low construction costs and low operating cost characteristics; Meanwhile easily achieve machine none-maintenance requirements.

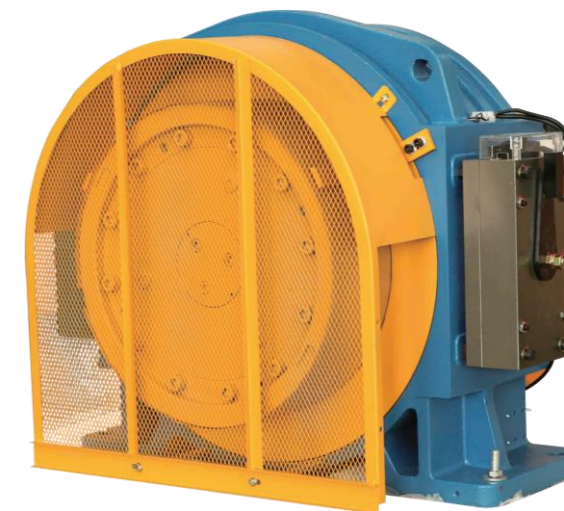

Freight Elevator

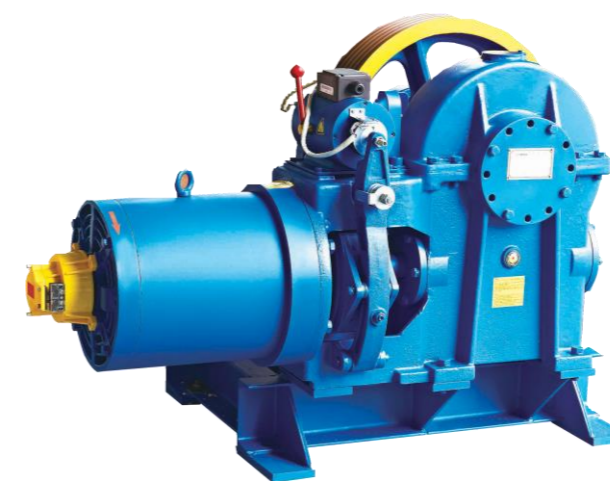

A gear traction machine

Mature technology, high reliability
 Fine durability
 Smooth running
 Firm and durable
 The main use of machine room elevator

AC variable frequency door operator

Apply advanced technology VF door operator control systems, AC variable frequency motor and door mechanical system, not only to improve the safety and sensitivity of elevator operation, but also save energy consumption, adapted to the growing demands of modern transport.



- Low Noise
- Environmentally Friendly
- Efficient and energy-saving
- Space-saving
- Stable And Reliable

Deceleration curve comparison

VF observation elevator use vector frequency transformer to full closed-loop control the elevator, the elevator greatly improved performance, lower operating power consumption, has a very superior cost performance

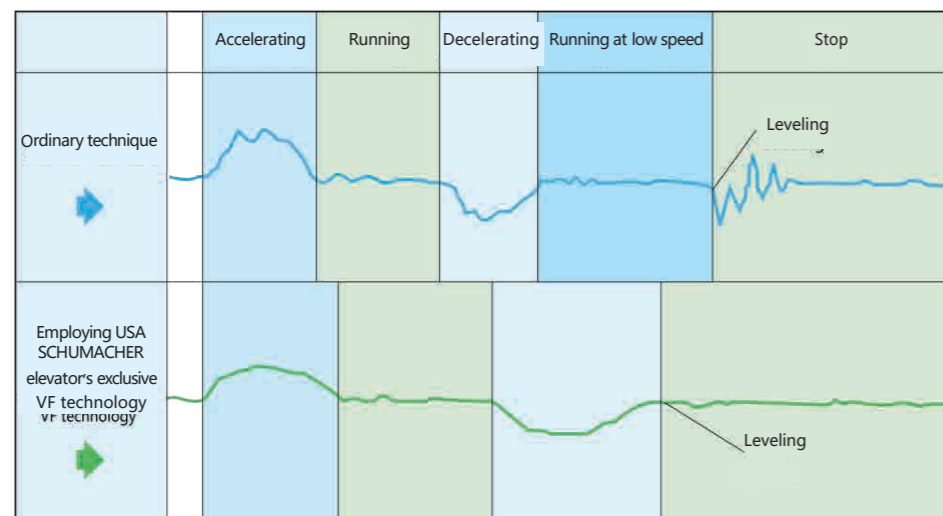

Low carbon emissions, to develop a sustainable society

Treat "low carbon", "recycling resources", "environmental protection" as three fundamental developments, actively promote to reduce environmental impact of global production within whole life cycle to produce and maintenance, in order to achieve social sustainable development.

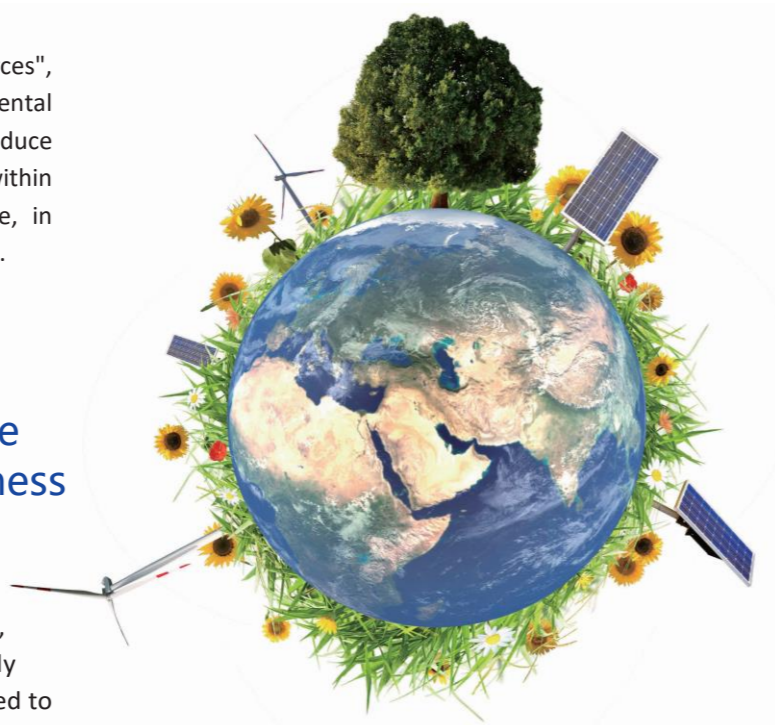

New generation VVVF technology to overcome the energy consumption weakness of traditional technology.

Schumacher elevator apply VVVF technology, the elevator running power and power supply capacity will be significantly reduced, compared to conventional AC speed drag energy, will save nearly 20%.

Safe, reliable, cost-effective

Schumacher serial freight elevators apply micro-computer control technology. It uses high intensity cars that have been designed and manufactured by section materials. It can transport the freight under extreme conditions. SCHUMACHER freight elevators conform to the European standard and the Chinese standard for manufacturing, installation and safety. The European code is referred to as EN81, The standard code for China is referred to as GB7588. SCHUMACHER freight elevator is your ideal choice in the factory, warehouse, department store, shopping center, housing property management center etc. because of its safe; durable and reliable properties, high structural strength, smooth operation, large door opening distance, high cost performance and so on.



Freight Elevator

Multiple door opening modes

In order to satisfy different entry/exit requirements from a broad range of users, SCHUMACHER freight elevator offers four door opening modes: side opening, center opening double-folded door, one-way door opening, opposite door opening. It's flexible design can accommodate the unique requirements of any factory, warehouse, department store, shopping center, housing property management center etc.

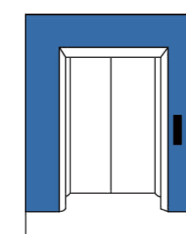

two panel sliding door

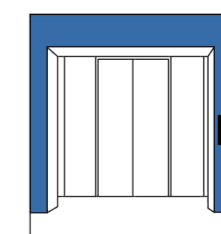

center-opening & double-folded

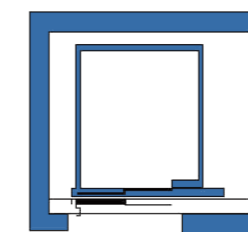

single way door

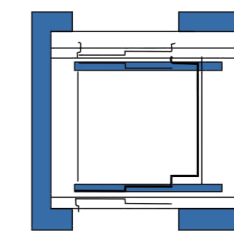

double way door

We will never let it happen, as the old saying "A miss is as good as a mile"

SCHUMACHER freight elevator uses a slight edge to lay the brand foundation. The product leveling accuracy can be controlled within mm level range.

More professional and considerate

Sensitive intensive infrared screens, in the elevator door forming screen protection safety net, for any access to its detecting location of people or objects are responsive, greatly improving the safety performance of.

Large width door opening, free entry/exit

For the convenience of free entry/exit of large bulk freight, The SCHUMACHER freight elevator series applies multi-folded car structures. It can reach maximum width when opening the car door.

The durable and anti-aging high-strength materials

Schumacher freight elevator not only applies high-intensity section materials to manufacture the cars, but also implements special reinforcement design to the car platform. It brings about the more durable and anti-aging products.

Machine-roomless Freight Elevator

Schumacher machine roomless elevator offers an infinite possibility for vast constructions

Schumacher machine roomless freight elevator have many energy-saving and loss-reducing ideas. It not only saves the building area, but also greatly increases design freedom, It is also very environmentally friendly. Compared with same load level for a freight elevator with machine room, it saves 25% of the electric energy and 10% of the building area.



Machine roomless freight elevator



Save construction space by 10%



Save energy by 25%

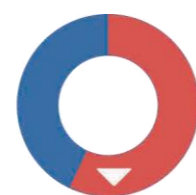

Reduce energy consumption by 35% -55%

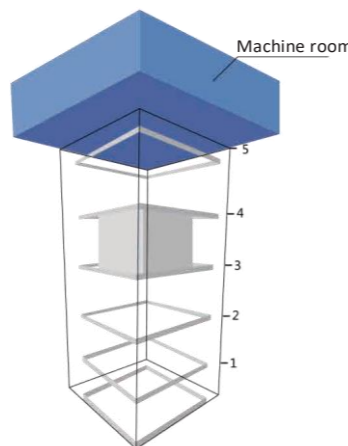

Machine room of normal elevator

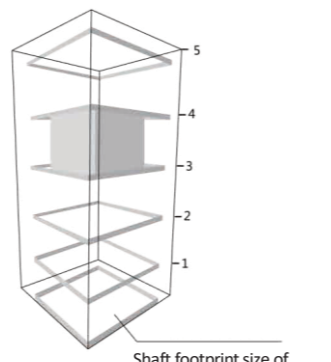

Machine room of machine roomless elevator

Shaft footprint size of machine roomless elevator



Freight Elevator

freight elevator different kinds of buildings.

Schumacher machine roomless freight elevator only needs a hoistway without a machine room. It brings about more design freedom to many different building designs.

Easy and effective installation

Easy installation it vital for freight transport in the elevator application. SCHUMACHER machine roomless freight elevator provides the customers with easy and effective installation plans. It ensures normal progress of the construction projects.

New generation variable frequency voltage regulation and speed governor technology

It is of the remarkable energy-saving, environmental protection, comfortable travel, maintenance-free, low noise and small size.

AC variable frequency door machine

The advanced technology not only saves energy, but also increases door opening/closing accuracy and ensures smooth travel of the door.

Standby & technology

When the elevator is in stand-by mode, it automatically cuts off the lighting and ventilator fan in the elevator.

Automobile Elevator

Escort you and the car

Schumacher car elevator take years of car elevator manufacturing technology from Schumacher USA, using highly sophisticated VVVF technology to precise control speed, avoid the noise and car jitter caused by traction system load increased because uneven stress of car, maximize optimization features of this series products.

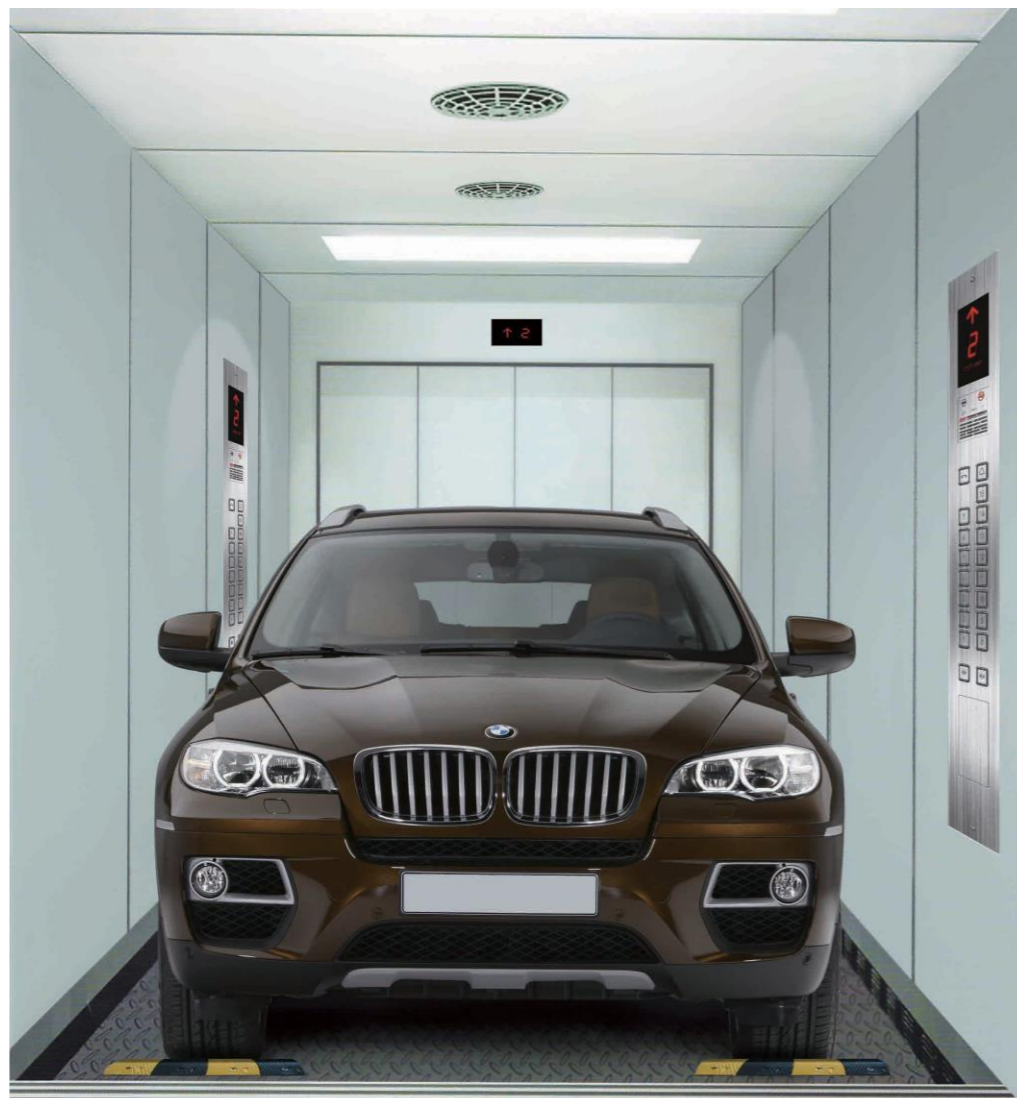

Dual operation buttons box

There are two push-button operation boxes in the car. Therefore the driver can operate the elevator in the car without stepping out of it.

Safety guide device

Safety guide device sets in the car ground to ensure fine security of both the automobile and the elevator.

Special display system

Special circuit control and display system is convenient for the drivers inside/outside the car.

Front/rear door opening are available

The elevator car is positioned between the front and rear door openings which is more convenient for the safety aspect and for the cars to enter into/exit from the elevator cars.

Dumbwaiter Elevator

Using industrial computer (PLC) or computer control, complete specifications, novel structure, fine workmanship, with safe, reliable, stable, easy to operate the car and landing doors made of high quality stainless steel plate production lines, luxury and beauty, widely used in hotels, restaurants and other units, is popular among customers.

Superior performance

Electric lock function: call the base station is equipped with electric locks ladder box, used to start and shut down the elevator control circuit;

Run fault protection function: When outside the normal run time of 10 seconds, the elevator stops, to prevent burn out the motor;

Fault self-display: the diagnosis of faults in code display;

Self-diagnostic capabilities: the ability to diagnose and identify the causes;

Restoring self-insurance function: if the control signal circuit short-circuit the insurance automatically disconnects when the failure to eliminate auto-connect after the insurance;

Contactor adhesion protection: If contactor coil power disconnected contacts unable to prevent the re-run to ensure safety;



Freight Elevator

Superior performance

Answer the call: Press the call button, the called elevator buttons light on, lights off after arriving;

Beeper function: When arrive, the beeper will remind;

Door status indicator: landing door open after elevator arrive, digital display door status and prompts this elevator is used in this layer;

Operating direction display function: the direction indicated by the vertical line luminous arrow;

Floor display: the floor(elevator arrive) is digital displayed;

Car Decoration And Design



Standard

- Ceiling paint steel (color optional)
- Car wall paint steel (color optional)
- Car door paint steel (color optional)
- Lighting Energy-saving fluorescent lamp
- Floor Corrugated steel



Optional

- Ceiling Hairline stainless steel
- Car wall Hairline stainless steel
- Car door Hairline stainless steel
- Lighting Energy-saving fluorescent lamp
- Floor Corrugated steel

Landing Door Series



Side opening & double-fold type

- Standard
- Jamb: Painted steel (optional color)
- Landing door: Stainless steel
- Sill: Iron-made



Side opening & three folded type

- Standard
- Jamb: Painted steel (optional color)
- Landing door: Painted steel
- Sill: Iron-made



Side opening & double-fold type

- Standard
- Jamb: Painted steel (optional color)
- Landing door: Painted steel
- Sill: Iron-made



Center-opening & double-folded type

- Optional
- Jamb: Painted steel (optional color)
- Landing door: Painted steel
- Sill: Iron-made

Freight Elevator

Car Operation Panel



SMK-201 (Standard)

Plate spray card



SMK-S010 Cream-colored

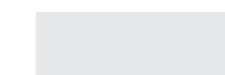

SMK-S020 Light gray



SMK-S030 Aurora Silver



SMK-S040 Apple green

Freight Elevator Civil Figure

Machine Roomless Freight Elevator Civil Figure

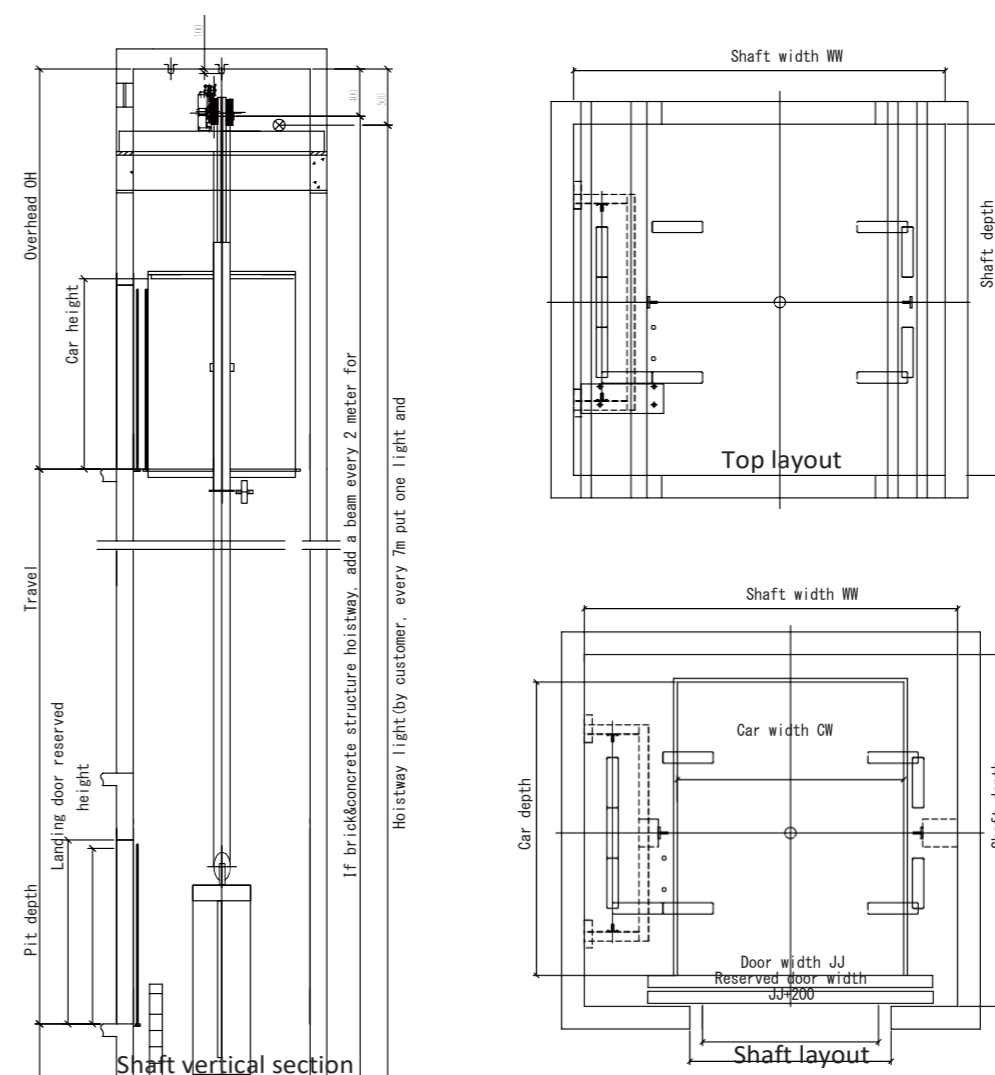
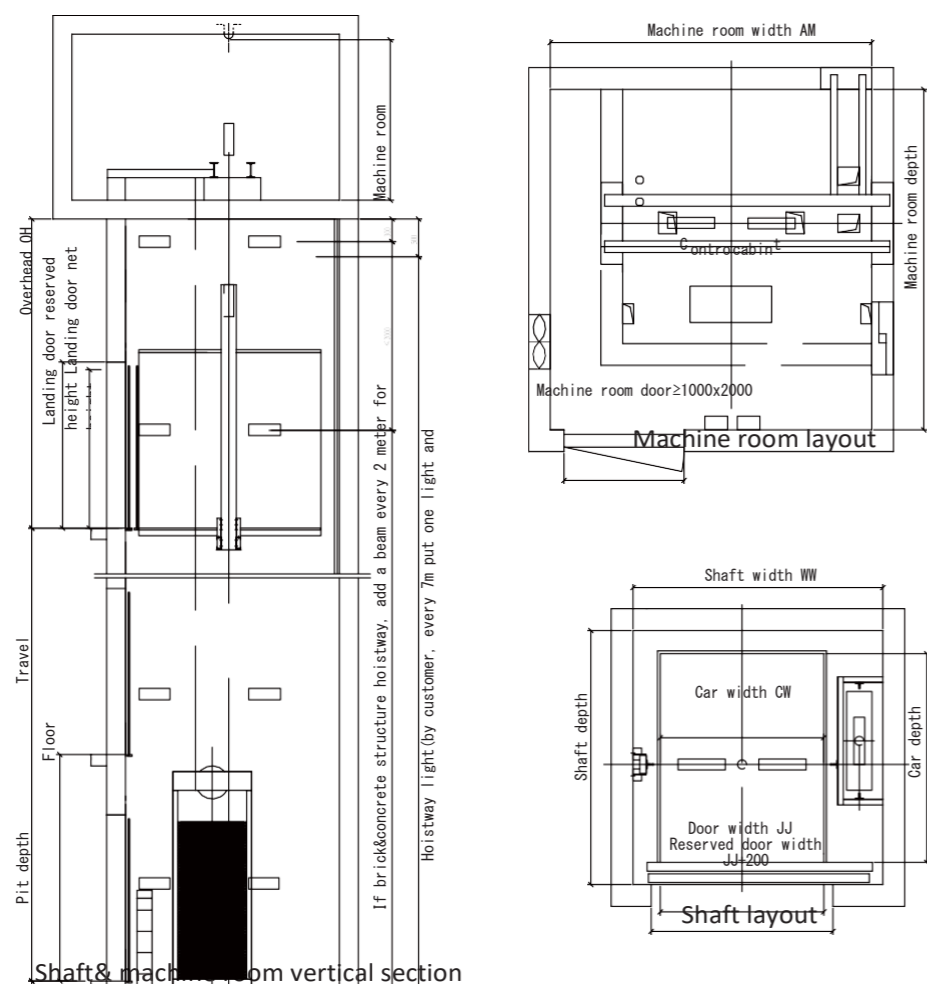

Standard machine room freight elevator Technical Data Sheet

Standard machine roomless freight elevator Technical Data Sheet

Capacity KG	Speed m/s	Door opening	Car dimension CW*CD*CH(mm)	Door size JJ*HH(mm)	Shaft size			Max. travel height TH(m)
					shaft width* shaft depth WW*WD(mm)	overhead OH(mm)	pit depth PD(mm)	
1000	0.5	sliding two panel	1400*1700*2200	1400*2100	2500*2200	4200	1400	30
2000	0.5	sliding two panel	1700*2400*2200	1700*2100	3000*2850	4200	1400	30

Capacity KG	Speed m/s	Door opening	Car dimension CW*CD*CH(mm)	Door size JJ*HH(mm)	Shaft size			Max. travel height TH(m)
					shaft width* shaft depth WW*WD(mm)	overhead OH(mm)	pit depth PD(mm)	
1000	0.5	sliding two panel	1400*1700*2200	1400*2100	2500*2100	4200	1500	30
2000	0.5	sliding two panel	1700*2400*2200	1700*2100	3050*2850	4500	1600	30
3000	0.5	center four panels	2000*2900*2200	2000*2100	3500*3350	4700	1700	30
4000	0.5	center four panels	2200*3300*2200	2200*2100	3850*3950	5200	1800	30

Note: the above for the civil diagram, detailed dimensions see construction plans, specific to the technical department to provide construction drawings.

Note: the above for the civil diagram, detailed dimensions see construction plans, specific to the technical department to provide construction drawings.

Car Elevator Civil Figure

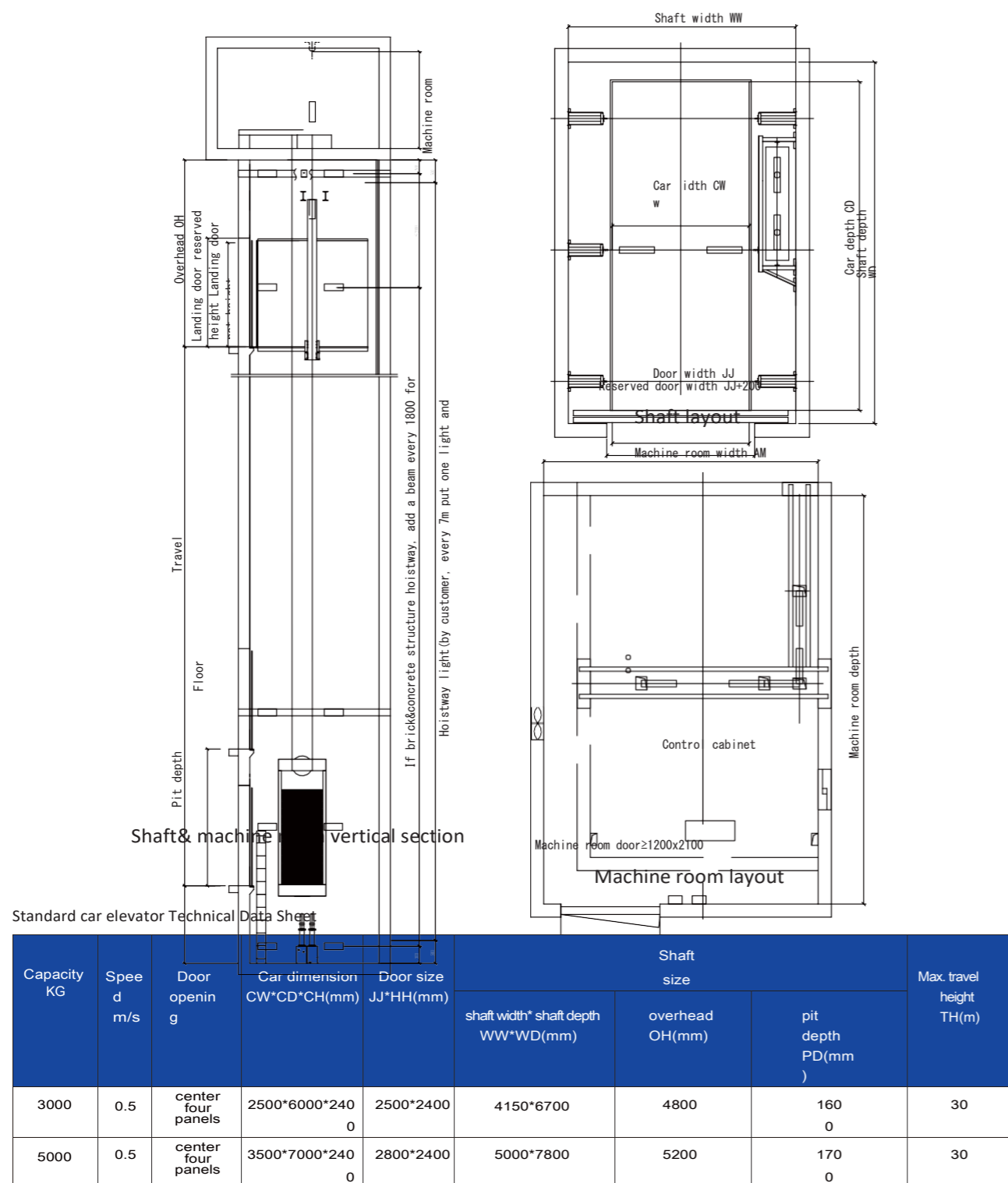

Note: the above for the civil diagram, detailed dimensions see construction plans, specific to the technical department to provide construction drawings.

Dumbwaiter Elevator Civil Figure

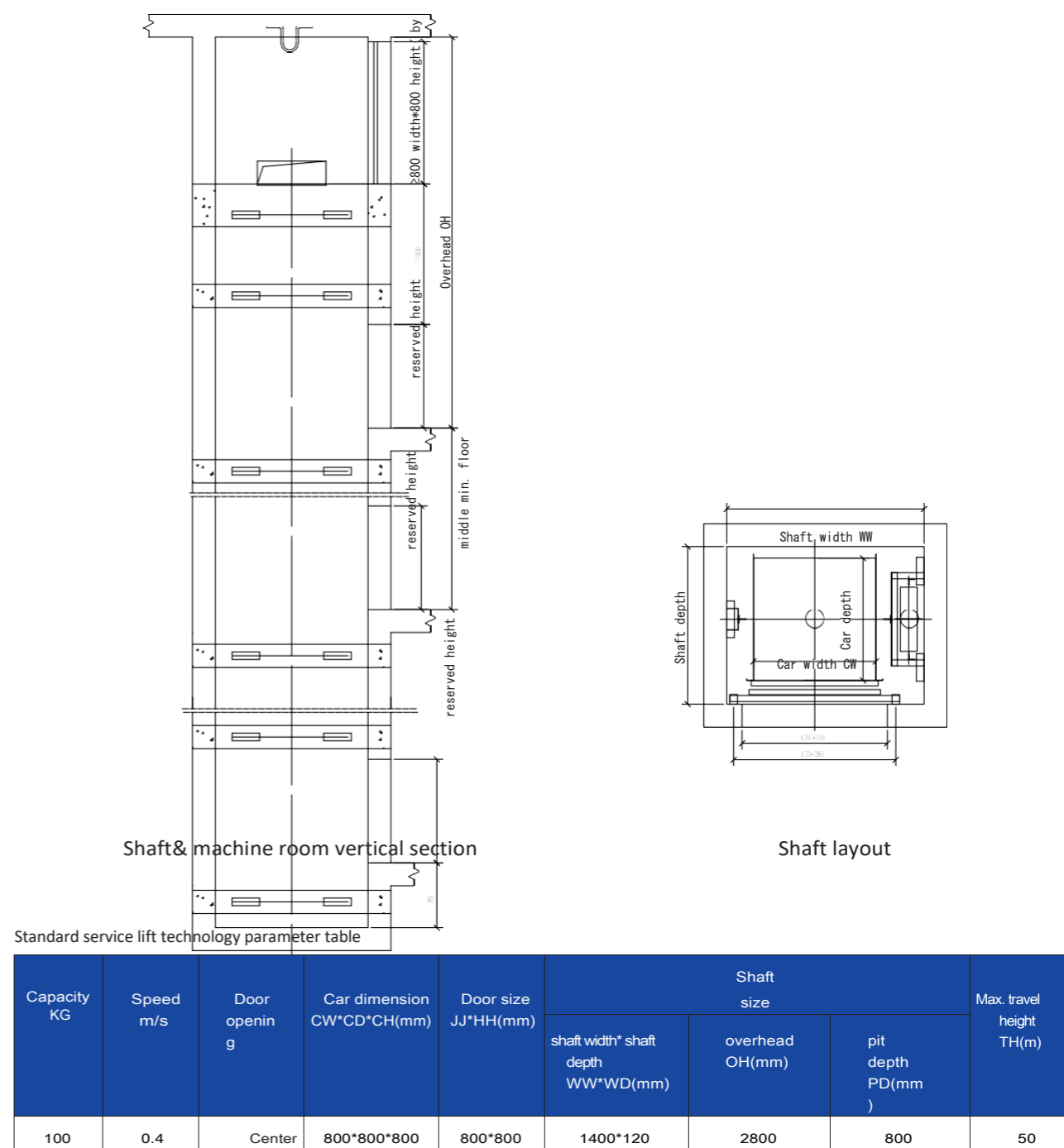

Note: the above for the civil diagram, detailed dimensions see construction plans, specific to the technical department to provide construction drawings.

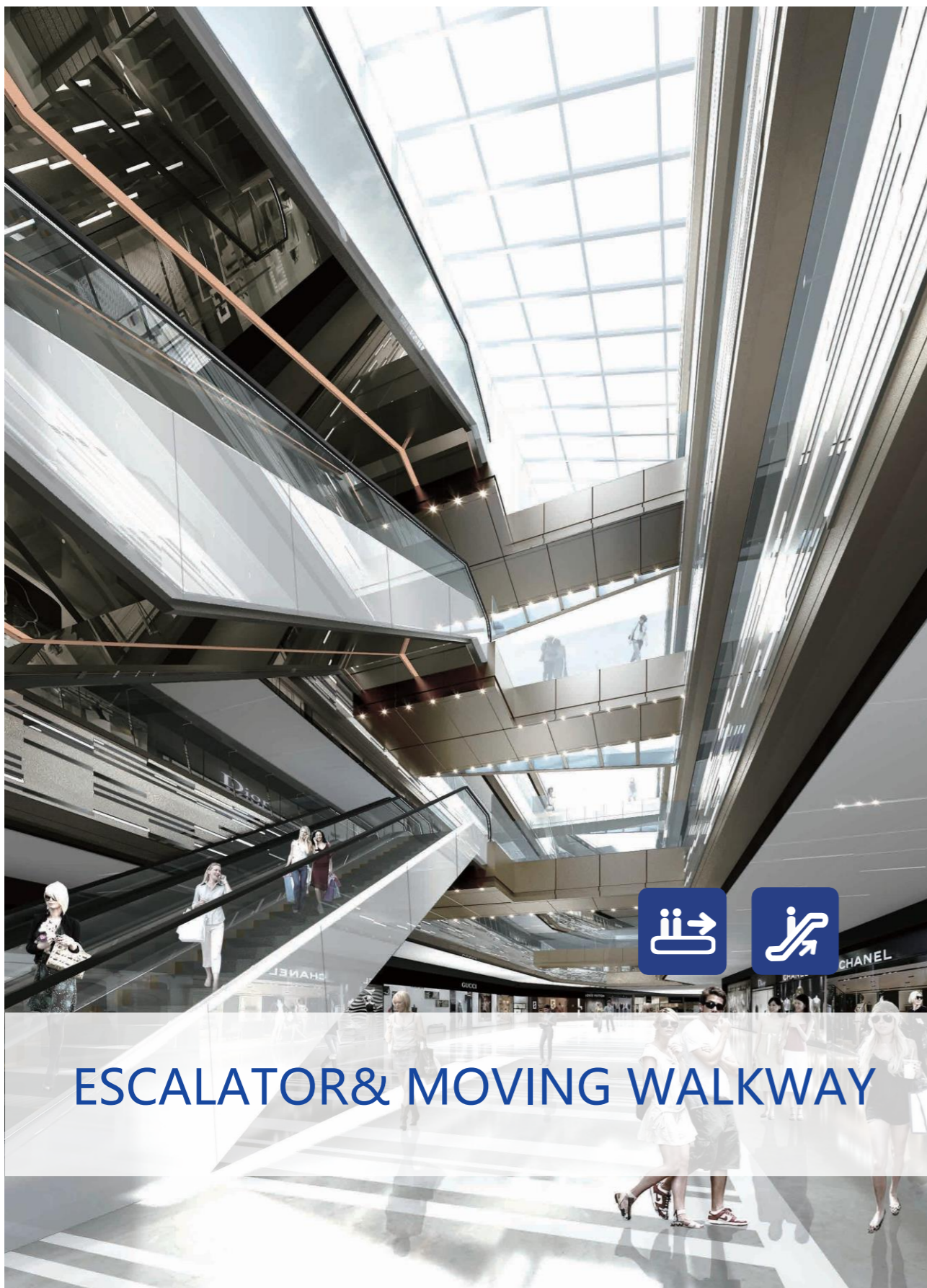

Escalator

Urban atmosphere, beautiful landscape

Schumacher serial escalators fully apply the unique materials and the advanced domestic and overseas technology for design and manufacture. The escalators have the consummate structure, elaborate stairway, delicate belt, attractive outline, They are widely applicable for large passenger flow areas such as the shopping centers, supermarkets, subways, airports etc. It adds a charming mobile view for very large buildings.

It has features such as smooth running, low noise, fine durability, convenient repair, fine and exquisite structure, consummate lift-way, remarkable belt-way, attractive outline model, magnificent design style with gentle modern flavor, A safe cozy and beautiful escalator can let you enjoy the pleasant and comfortable moment every day.

Schumacher serial escalator will exceed your expectations! It is widely applicable for the shopping center, supermarket, subway, airport etc. It adds movement and beauty to your buildings.

- 

Apply US ANSI standard, more safety
- 

All stainless steel design is more rugged, beautiful
- 

Unique 8mm safe border and yellow non-slip pattern border
- 

Streamlined Slim handrail is more ergonomic handrail
- 

Patented compact, concise handrails drive system

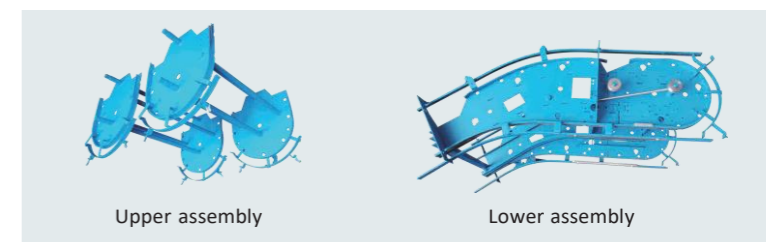

Extended life

It adopts the metal beam with light weight and high tensile strength. In this way, it ensures the integral rigidity of the products. The automatic lubricating system can guarantee the prompt and automatic parts fueling which extends the useful life of the products.

Beautiful appearance

The super-consciousness aesthetical design, technological design which conforms with the ergonomics principle. It keeps close to the latest global tide and forms a perfect harmony with the buildings and the surrounding environments.

Very smooth

It adopts the advanced control system and decelerator. The superior drive chain and precise installation technology ensures that the product runs smoothly.

Very safe and reliable

It strictly executes the current Chinese and European standards such as GB16899-2011 safety criteria for the production and installation of escalator and auto-walk etc. It has set all the necessary safety devices, adopted the micro-computer control technology, fulfilled non-contact control with safe and reliable running.

Accurate open & close control

It adopts the high tensile strength metal structure which makes it appear more compact for the product outline dimension.

Continuous monitoring

The super CPU main board monitors the operation in real time. If any abnormal situation occurs, it automatically brakes and records the malfunctions code.

Passenger Conveyor

As Easy As In Smooth Ground,
The Everlasting Popular Design & Quality

In colorful modern city, supermarkets, public buildings, airports, exhibition centers and transport interchanges and other public transport situation, moving walkways due to its characteristics, not only to meet the huge flow of people's transport problems, but also to meet walking long distances and transport baggage cart, stroller, shopping cart, disabled vehicle, etc. when people take escalator to upstairs and downstairs, they will feel like the ground cover, a great convenience to people's travel and shopping. It is convenient, fast and pleasant ride demands, thereby has become first solution for supermarkets, airports, exhibition centers and transport interchanges.

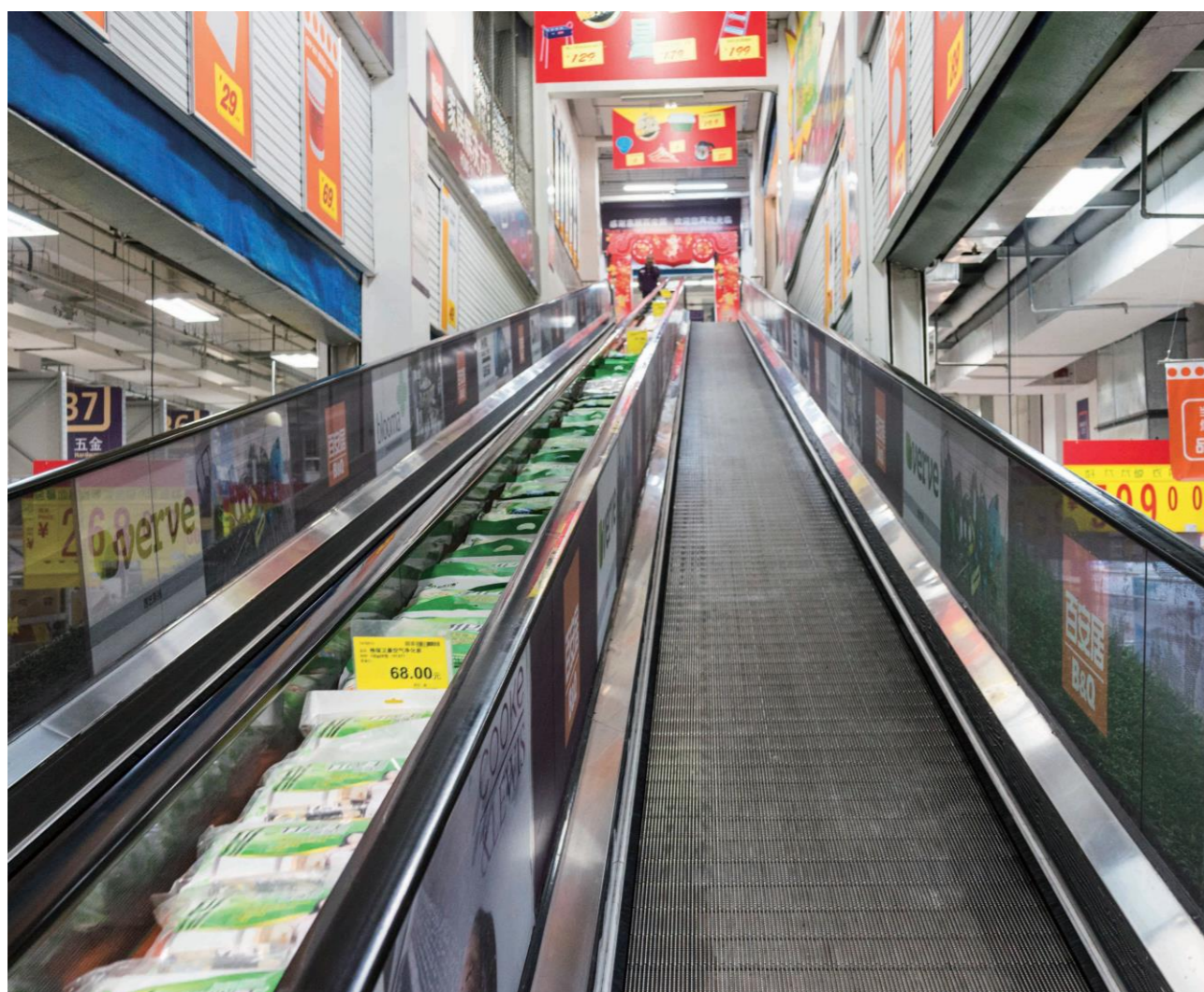

The Performances Advantage

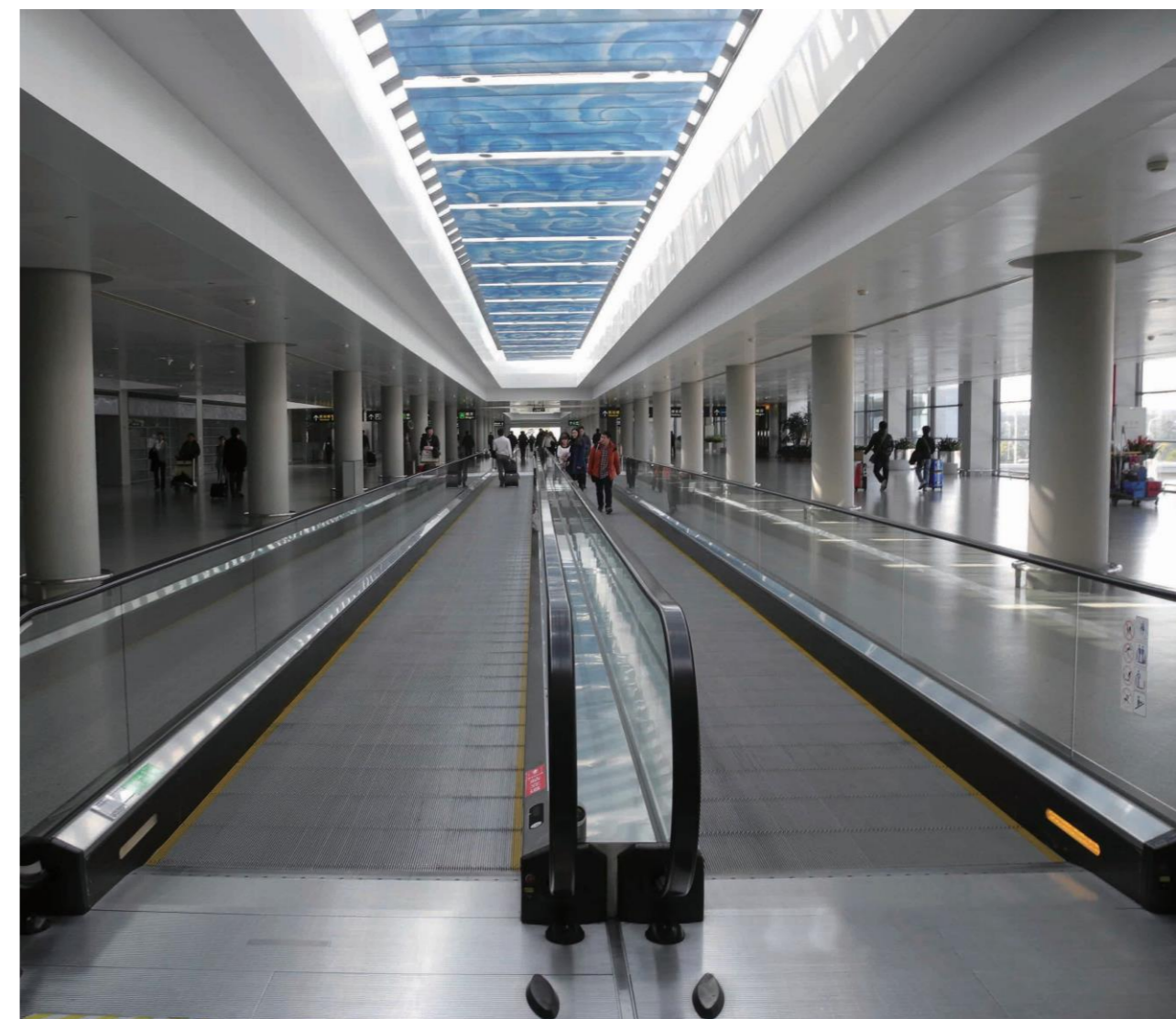

It blends with modern design and style.

The stairway guide rail design with armrest fixes the whole stairway running in guide rail, it controls the stairway movement, avoids friction between the steps, skirting and comb teeth, It is convenient for installation, adjustment, repair and maintenance, It greatly increases the running effects.

High efficiency & energy-saving

Customer can choose VVVF control to control running speed, the energy saving performance is obvious, It can prolong product life and reduce the operation cost.

Escalator Safety Device

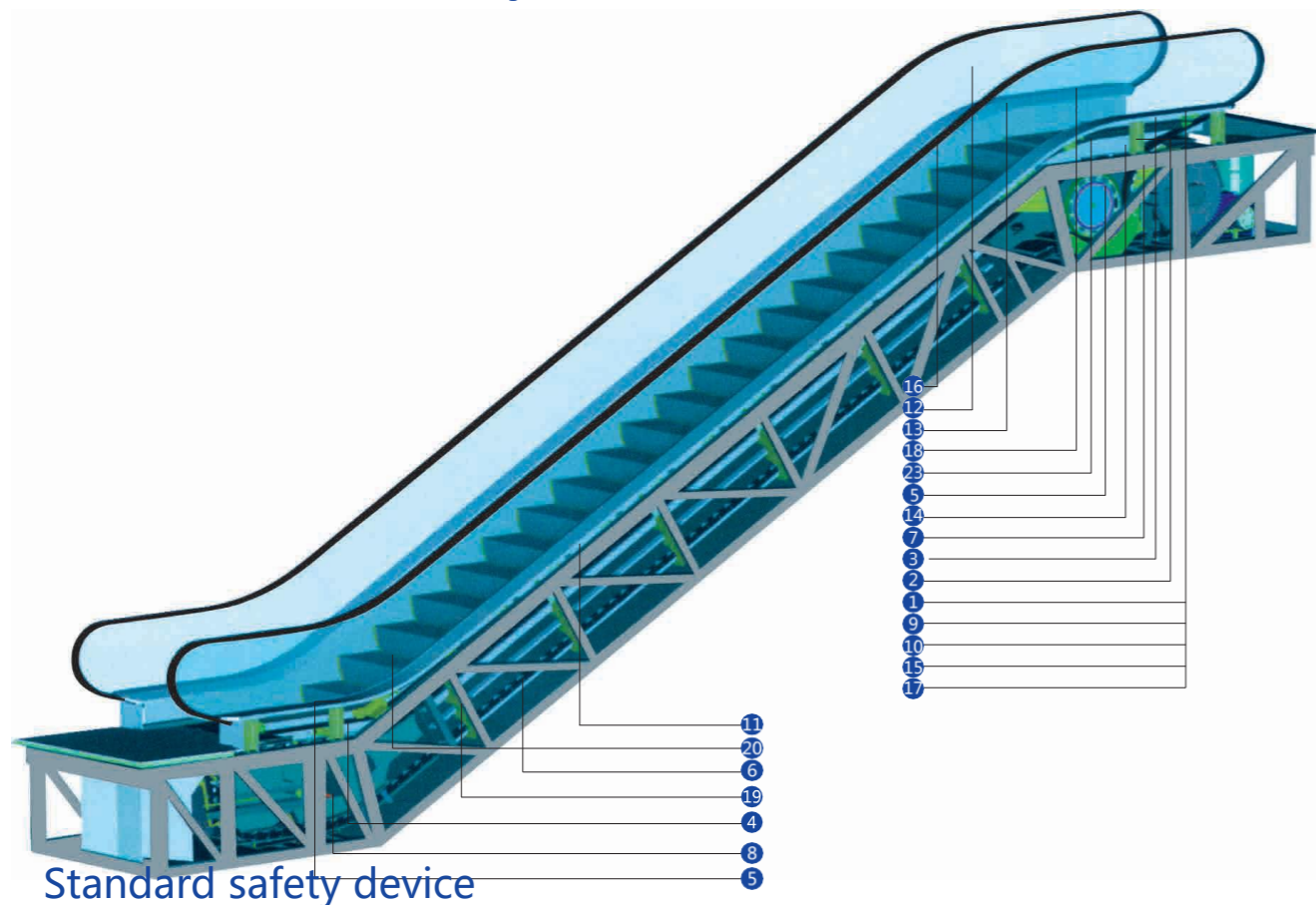

Standard safety device

1. Lack of phase, error phase protection

If lack phase or error phase has been checked out, the escalator (auto-walk) will automatically stop the operation.

2. Motor over-load protection

When the current exceeds 15% of the current rating, the escalator will automatically stop the operation.

3. Electrical appliance loop protection

It offers the automatic circuit disconnecting device to protect the circuit and main components of the escalator (auto-walk).

4. Handrail inlet protection

When some foreign substance has been clipped in the handrail inlet, the escalator (auto-walk) will automatically stop the operation.

5. Comb plate safety device

When some foreign substance has been clipped in or between the combs, the escalator (auto-walk) will automatically stop the operation.

6. Step sagging protection device

When there is abnormal step bending, the escalator (auto-walk) will stop the operation before the step entering into the comb plate.

7. Broken drive-chain safety device

When the drive-chain has been over-stretched or it is broken, the escalator (auto-walk) will automatically stop the operation.

8. Broken step chain protection

When the step (pallet) chain has been over-stretched or it is broken, the escalator (auto-walk) will automatically stop the operation.

9. Over-speed protection

When there is over-speed to the escalator (auto-walk), it will automatically stop the operation.

Passenger Conveyor Safety Device

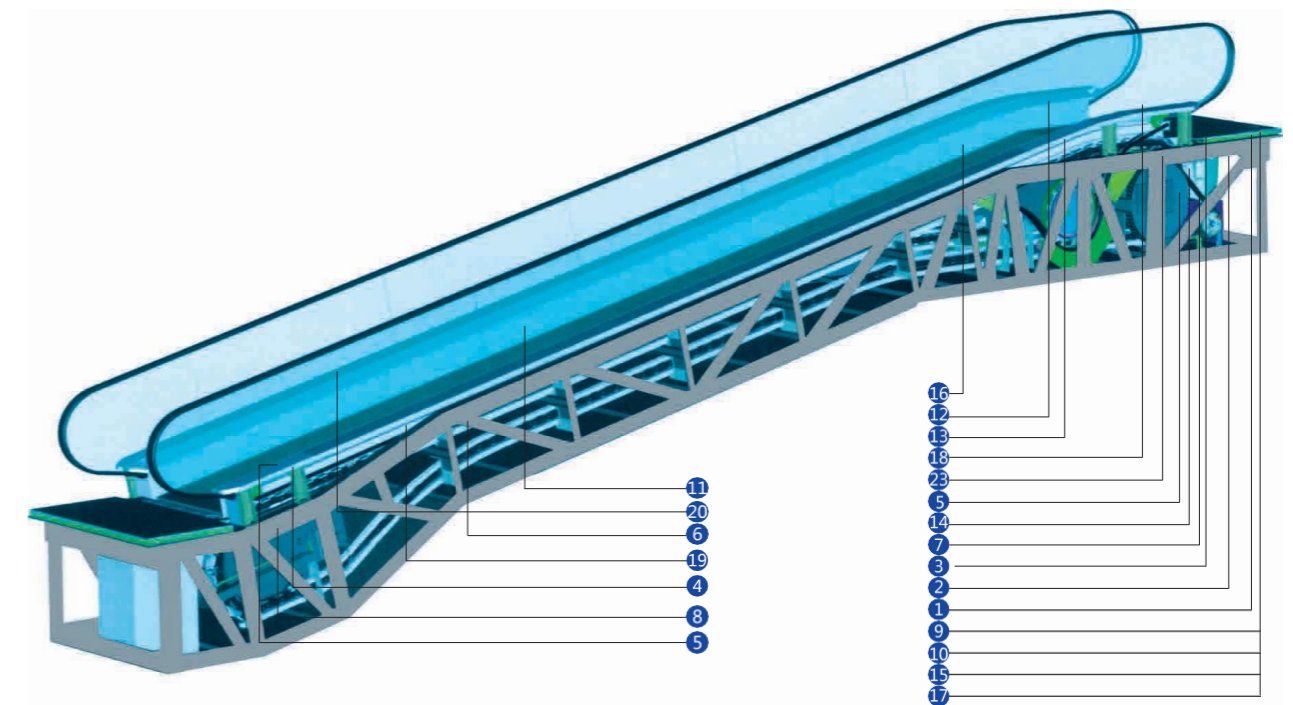

10. Direction reversal protection

When it comes the unintentional reversal of the direction of travel, the escalator (auto-walk), will automatically stop the operation.

11. Security line

The yellow synthetic resin security line is located in the front position and two sides of the escalator tread so that the passengers will not tread in-between the edge of the adjacent step and the lift group lengthened skirt panel, The security line on both sides of the step is higher than tread surface, (The auto-walk offers the selective yellow spray-painted security line.)

12. Emergency button

When the button has been pressed down, the escalator (auto-walk), will stop the operation.

13. Skirt panel protection

When some foreign substance has been clipped in between the skirt panel and the step, the escalator (auto-walk) will automatically stop the operation.

14. Brake protection

When the electric force falls short of supply or it acts any of the safety device, the brake function goes into effect by the safety device through the spring resilience action, In this way, the escalator (auto-walk) stops the operation.

15. Safety inspection switch

It is a safety device to prevent from the escalator starting during the inspection and maintenance.

16. Warning lights

Illumination exists in the upper and lower ends of the escalator, in the lower part of the step in order to remind the passengers of the security matters.

17. Alarm bell starting device

The alarm bell rings when it starts the escalator in order to remind the passengers of the security matters.

18. Control device for handrail breakage

When the handrail is broken, the escalator will automatically stop the operation.

Construction Parameters

30°VF-escalator

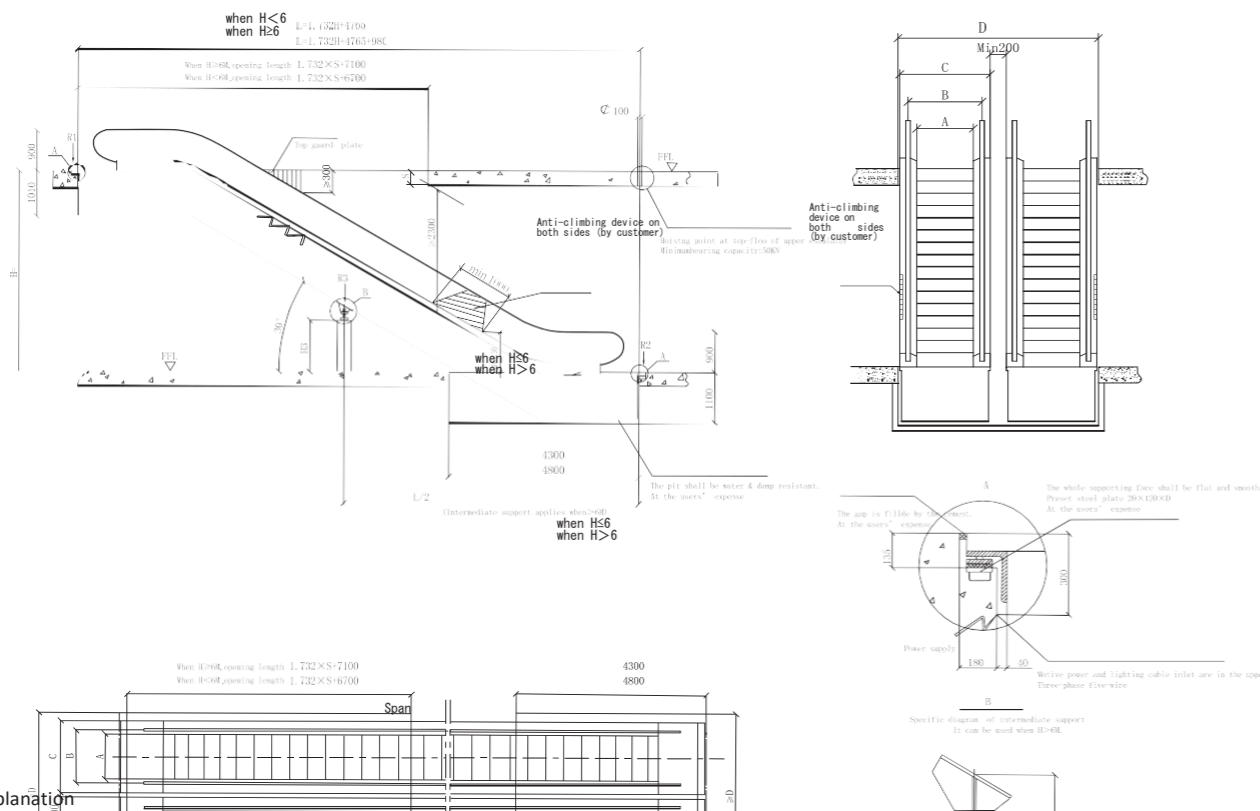

Explanation

- When the escalator is installed up to second floor, cancel pit, civil substructure and the upper symmetrical pit should be waterproof by customer.
- The upper and lower escalator entrance should have sufficient flow area, depth dimension from the front end to the steering handrail obstacle should be not less than 2500mm.
- users to provide a ground resistance which is less than 4Ω. Current power wiring should be three-phase five-wire system by customer.
- Truss decoration on three sides by customers, decorated weight should less then 30Kg / m2.
- All dimensions in mm, subject to change without notice.
- The figure "S" represents floor beam thickness.

1000	1000	1238	166	350
			0	0
800	800	1038	146	310
			0	0
Step width	A	B	C	D

Type Mode	Travelling height mm	Net weight (two set) KN	Support(two set)		Motor power KW	Cab Dimensions	
			R1 KN	R2 KN		h	l
Fml-302(800) (4800persons/h)) speed:0.5m/s	3000	118	104	94	5.5	2080	10900
	3500	126	112	100		2110	11890
	4000	134	120	108		2140	12880
	4500	142	128	114	8	2160	13870
	5000	148	136	120		2170	14860
	5500	164	148	132		2190	15860
Fml-302(1000) (6000persons/h)) speed:0.5m/s	6000	172	156	138	11	2200	16850
	3000	126	118	106	5.5	2080	10900
	3500	134	128	114		2110	11890
	4000	142	136	122		8	2140
	4500	150	146	130	2160		13870
	5000	166	158	142	2170		14860
	5500	174	168	150	11	2190	15860

Note: when lifting height >6m, civil dimensions please consult our company

Construction Parameters

35°VF-escalator

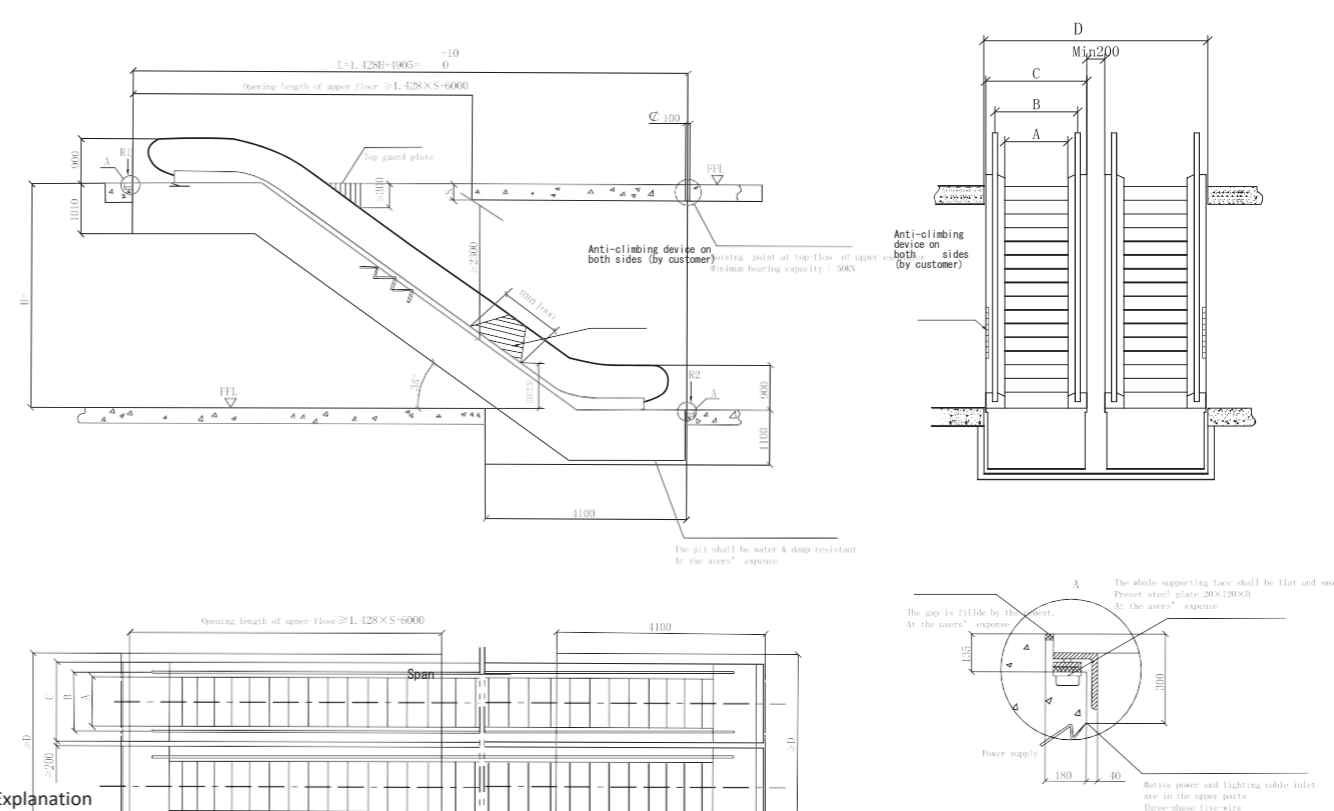

Explanation

- When the escalator is installed up to second floor, cancel pit, civil substructure and the upper symmetrical, pit should be waterproof by customer.
- The upper and lower escalator entrance should have sufficient flow area, depth dimension from the front end to the steering handrail obstacle should be not less than 2500mm.
- users to provide a ground resistance which is less than 4Ω. Current power wiring should be three-phase five-wire system by customer.
- Truss decoration on three sides by customers, decorated weight should less then 30Kg / m2.
- All dimensions in mm, subject to change without notice.
- The figure "S" represents floor beam thickness.

1000	1000	1238	166	350
			0	0
800	800	1038	146	310
			0	0
Step width	A	B	C	D

Type Mode	Travelling height mm	Net weight (two set) KN	Support(two set)		Motor power KW	Cab Dimensions	
			R1 KN	R2 KN		h	l
Fml-302(800) (4800persons/h)) speed:0.5m/s	3000	112	98	88	5.5	2180	10180
	3500	120	104	94		2220	11030
	4000	126	112	100		2250	11890
	4500	132	118	106	8	2270	12750
	5000	140	124	112		2300	13610
	5500	146	130	118		2310	14470
Fml-302(1000) (6000persons/h)) speed:0.5m/s	6000	152	138	122	11	2330	15330
	3000	120	112	100	5.5	2180	10180
	3500	126	118	106		2220	11030

Center support H3(L/2-2600)×tg30°-(897/cos30°+300)

Construction Parameters

VF-moving walk

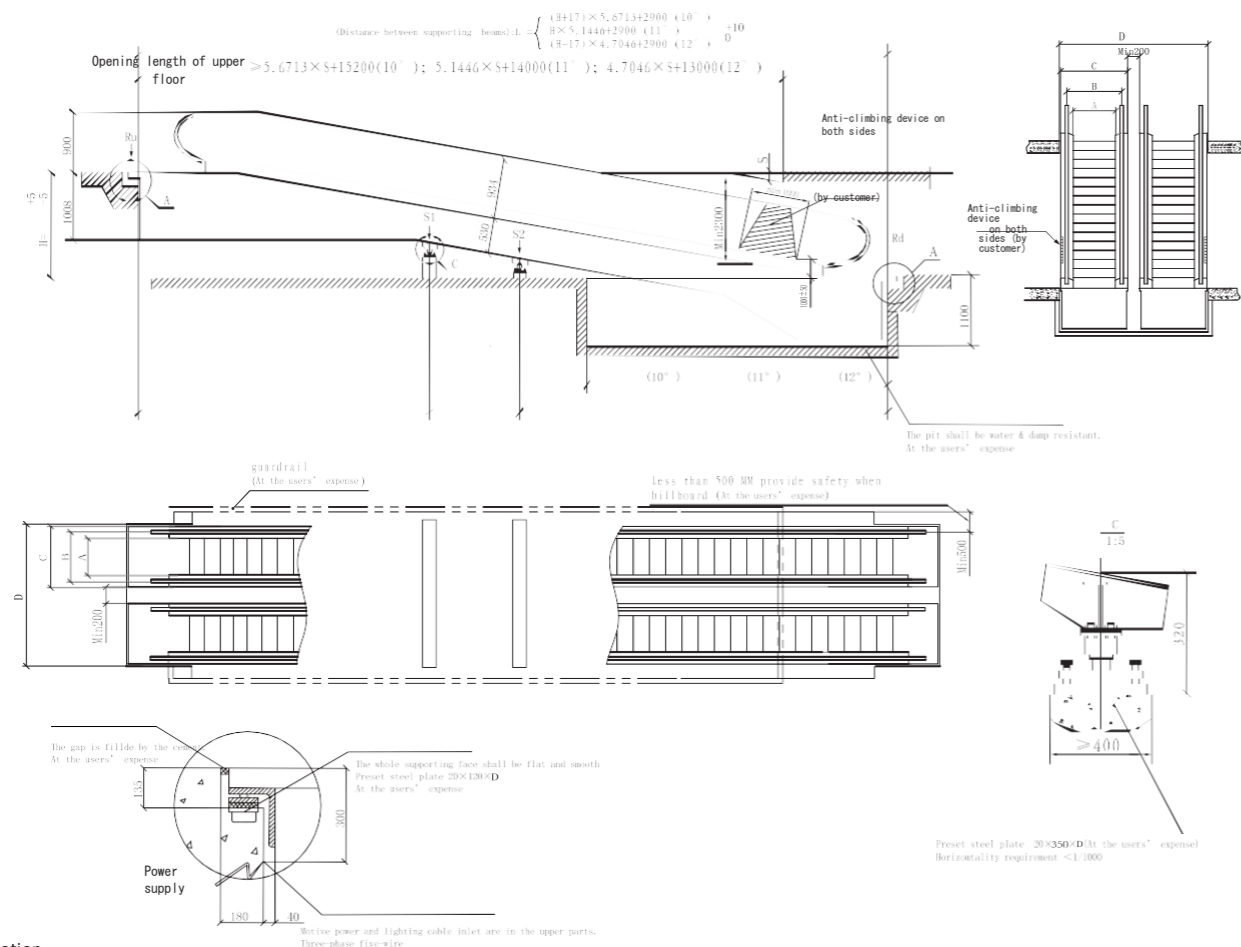

- Explanation**
- When the moving walkway is installed up to second floor, cancel pit, civil substructure and the upper symmetrical, pit should be waterproof by customer.
 - Moving walkway entrance should have sufficient flow area, depth dimension from the front end to the steering handrail obstacle should be not less than 2500mm.
 - users to provide a ground resistance which is less than 4Ω. Current power wiring should be three-phase five-wire system by customer.
 - Truss decoration on three sides by customers, decorated weight should less then 30Kg / m².
 - All dimensions in mm, subject to change without notice.
 - When step is aluminum material, please ask for civil size from us
 - The figure "S" represents floor beam thickness.
 - Supporting force is approximate; all dimensions in millimeters (mm); all loads
- Units are KN; Will be without notice if change.

Supported by force	q	M	N	
RML800	0.0039	9.5	4.5	
RML1000	0.0045	11	5	
RML800	800	103	146	326
		8	0	0
RML1000	1000	123	166	366
		8	0	0

Tiltangle	Ris e		Intermediate support		La	Lb	Lc
	from	to	S1	S2			
	10°	127 3	215 4	-			
	215 5	338 8	1	-	7000	L-7000	-
	338 9	479 9	1	-	L-15000	15000	-
	480 0	600 0	1	1	7000	15000	L-22000
11°	142 3	239 4	-	-	-	-	-
	239 5	375 4	1	-	7000	L-7000	-

Escalator Arrangements Planning

Single unit arrangement

particularly suitable for transporting passengers between two floor levels, where passenger flow is in one direction, although on-demand starting can be utilized to allow travel in both two directions, (e.g, up in the morning and down in the evening).

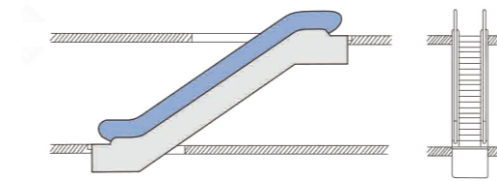

Continuous arrangement (one travel direction)

Mainly suitable for small department stores, between three sales floor levels, More space required than the interrupted arrangement.

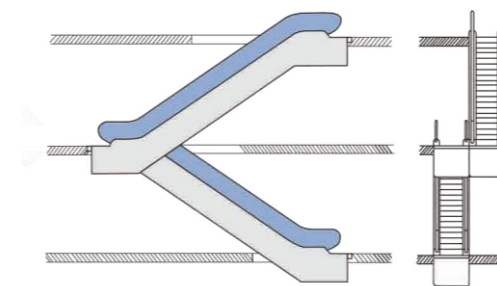

Interrupted arrangement (one travel direction)

Passengers have to make a short detour to the next escalator, strategically placed displays alongside the route of this detour can help to increase sales by encouraging impulse buying.

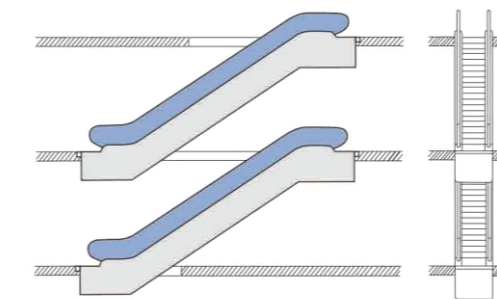

Multi-level parallel arrangement (interrupted traffic, two travel directions)

Mainly used in department stores and public buildings with a heavy traffic flow, When there are three or more escalators, the possibility to reverse the direction of travel of both escalators depending on the usage or traffic flow, this arrangement is economical, since no decorative truss cladding is required.

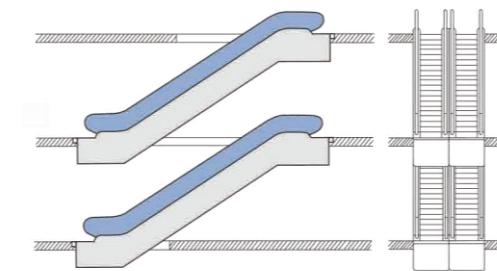

Multi-level criss-cross arrangement (continuous traffic flow, two travel directions)

Mainly used in major department stores, public buildings and public transport buildings, reduce congestion at the landing area by separating upwards and downwards travelling passengers.

